

STARCON

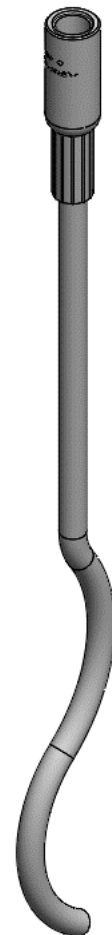

STARCON



Lifting Socket with long-wavy Tail Bar 0.5S to 12.5S

User and design manual

Lifting and handling systems for concrete elements.

1 Nomenclature

Symbol	Description	Unit
α	Diagonal pull angle between sling and axial direction	°
β	Tilting angle between element and axial direction	°
γ	Turning angle between element and horizontal direction	°
°C	Temperature Celsius	°C
σ_{ele}	Concrete strength of the element at the time of lifting	MPa
B	Minimum plate thickness of a tile/slap/deck	mm
COG	Center of gravity	[–]
D_{bar}	Bending diameter of 90° pull bar	mm
d_{bar}	Diameter diagonal pull bar	mm
D_{s1}	Bending diameter of additional reinforcement	mm
d_{s1}	Diameter additional reinforcement	mm
F_S	Load in diagonal direction	N
F_Z	Load in axial direction	N
F_L	Load in lateral direction	N
K	Nailing plate embedding depth in the concrete element	mm
L	Length / height of the anchor	mm
l_{bar}	Length of the diagonal pull bar	mm
l_{s1}	Length of additional reinforcement	mm
S	Load group symbol (STARCON)	–
S_R	Minimum thickness of precast element	mm
S_Z	Distance between Transport anchors	mm
WLL	Working Load limit	ton

Table 1 Nomenclature

Starcon Precast Concrete Design & Lifting Manual

1	Nomenclature	1
2	Identification.....	2
3	Introduction Lifting Socket with long-wavy Tail Bar 0.5S to 12.5S	3
4	Safety instructions before use	4
5	Advantages of the Starcon system.	4
6	Using the Starcon system.....	5
7	Safety factors for lifting systems:	6
8	General information	7
9	Design method.....	8
10	Recommend extra support for transport anchors with rebar long wave in concrete walls ...	12
11	Starcon transport anchors with standard reinforcement included.....	14
12	General safety information when using the Starcon system.	16
13	Maintenance and inspection	18
14	Disposal / Recycling	19
15	Product data of Lifting Socket with long-wavy Tail Bar	19
16	Product data of Lifting loop	20
17	Product data of Alpha inclined pull lifting loop	21
18	Product data of Goliath Lifting Loop 40.8.....	22
19	Product data of nailing plates for transport anchors	23
20	EC – Declaration of Conformity of the Machinery.....	24

2 Identification

Table 2 provides insight into the revision number of this document. It facilitates tracking changes and ensuring version control for accurate referencing and updates.

Version	Responsible	Creator	Date	Comment
A	CERTEX Denmark	JLJ	06-09-2024	New documentation

Table 2 Revision table

3 Introduction Lifting Socket with long-wavy Tail Bar 0.5S to 12.5S

Read this instruction manual before using the Lifting Socket with long-wavy Tail Bar.

Incorrect use can cause injury or danger!

Safety is paramount when using lifting devices and equipment.

Only trained individuals should operate them as per national law.

Familiarize yourself with the instruction manual before use to ensure safe operation. Adhering to these guidelines reduces the risk of accidents.

Consult relevant national regulations as they may supersede these instructions.

All individuals involved with the equipment must read and understand this manual. Contact Certex for assistance or clarification.

Always keep the manual with the product. Contact information is provided on the last page.



General concept of the use Transport anchor with rebar-straight:

The Starcon Lifting and Handling System consists of three key components: Lifting Socket with long-wavy Tail Bar, lifting loop, and Starcon nailing plate shown on Figure 1.

To ensure proper placement of Lifting Socket with long-wavy Tail Bar in the finished concrete product, the head of the Transport Anchor is assembled into a corresponding Starcon nailing plate before pouring. Once the concrete reaches a strength of at least 15 MPa, the nailing plate can be removed, and transport can commence at the factory. At the installation site, transport can only begin once the concrete has reached a strength of at least 25 MPa. Contact CERTEX DK for lower strength values. Transport can be initiated by attaching the respectably rated lifting loop to the head of the Starcon Transport Anchor.

The Starcon transport anchors and systems use the guidelines described in the German guidelines VDI/BV-BS 6205 and Technical Report CEN/TR 15728, combined with EN 13155-2009. This ensures the highest level of safety when using our products.

Material:

Steel.

Surface treatment:

White zinc plated (WZP).

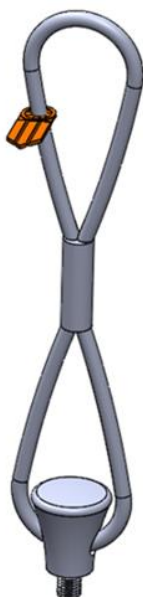

Goliat wirestrop



Lifting Socket with long-wavy Tail Bar

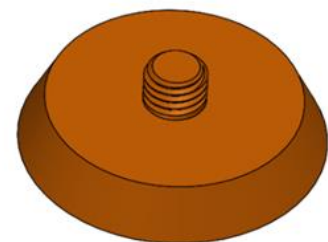

Nailing plate

Figure 1 Starcon lifting system.

4 Safety instructions before use

- The Starcon Transport anchor with rebar long waves must only be installed on a Starcon nailing plate of the same rating.
- Starcon Transport anchor with rebar long waves that are exposed to corrosion, or damaged must not be used.
- The Starcon Transport anchor with rebar long waves must only be hoisted by a lifting loop of the same size.
- The Starcon lifting and handling system must not be used to lift more than the specified load.
- The Starcon lifting and handling system must not be used for personnel lifting.
- The Starcon products are designed for one-time lifting only.
- The Starcon lifting system must only be used by skilled, trained employees.
- A lifting accessory used with the lifting loop must be correctly marked and approved for lifting.
- Before use, check the weather conditions. Never operate the system if there is a likelihood of lightning in the area and avoid use in extreme weather conditions such as storms, heavy rain, or snowing.
- The concrete safety factor assumes a factory production control complying with EN13369. If these requirements are not fulfilled, a safety factor of $\gamma = 2,5$ shall be used.
- All relevant concrete failure modes shall be verified by the pre casting manufacturer of the concrete elements; the different failure modes and verification methods are specified in EN13155 (Annex H).

5 Advantages of the Starcon system.

The Starcon system offers transport anchors with rebar long wave. These specialized fasteners are used to safely lift and secure precast concrete elements during transportation and installation.

The Starcon system is available in load groups 0.5S to 12.5S. It is typically embedded in the concrete element during the prefabrication stage and provides a secure lifting point for cranes or hoists. Transport anchors with rebar straights allow for the attachment of lifting loops or other rigging hardware.

The system's efficiency has been proven through many years of successful use and numerous laboratory tests. Components are regularly tested during production and are clearly marked with the maximum load. The transport anchors with long waves are individually tested and come with a traceability batch code.

5.1 Note

The information in this manual is for guidance only, and the use of the manual does not in any way exempt the manufacturer from ensuring that the chosen lifting system is suitable for the intended purpose. The information and data listed in this manual only refer to original Starcon products supplied by *CERTEX DANMARK A/S*.

6 Using the Starcon system

The Starcon system comprises a wide range of anchors in a load group from 0.5S to 12.5S per anchor with various lengths. The principle for using the system is the same for the entire range. The Starcon system consists of the following three main components:

6.1 Lifting Socket with long-wavy Tail Bar

Lifting Socket with long-wavy Tail Bar is a steel embedded member with a specially designed foot for secure anchoring in hardened concrete. The Starcon transport anchors head, a cylindrical, internally threaded unit, connects to the Starcon lifting loop. Starcon transport anchors with rebar long waves are clearly labelled with dimensions (e.g. 1.2S) and are available in a variety of lengths. They undergo specimen testing for defects, dimensional deviation and tensile strength with a minimum safety factor of 3:1 against metal failure.

6.2 Starcon Nailing plate

The nailing plate, typically made of round plastic components with a threaded end, must be carefully attached to the anchor head and positioned correctly before being securely fastened to the formwork. After the concrete cures and hardens, the nailing plate is removed, exposing the anchor head seated in a cylindrical depression. Since the nailing plate is typically stripped and unscrewed during removal, it's not normally reusable.

Nailing plates, made of steel and plastic components, can be disassembled, unscrewed, cleaned, and stored for reuse after removal.

6.3 Starcon Lifting Loop

Lifting loops are devices used to attach cables or slings to objects for lifting. Typically made of forged steel, they come in various shapes and sizes to suit different lifting capacities and applications. Lifting loops undergo rigorous testing to ensure their safety. Each loop is marked with its article number, identification number, and maximum working load, along with a clear indication of a 4:1 safety factor.

An additional safety measure is that the Starcon system is available in several non-compatible load groups. It is not possible to incorrectly assemble components from different load groups, thus avoiding failure of the lifting arrangement.

6.4 Lifting loop assembly instructions.

Screw the lifting loop by hand into the threaded hole of the transport anchor. Ensure the threads engage fully and easily without any cross-threading. If necessary for proper sling alignment during lifting, you may loosen the connection by one turn of the lifting loop. The system allows safe lifting in a vertical direction and up to a maximum tilt angle of 45 degrees in all directions. The instruction is shown and explained in Table 3.

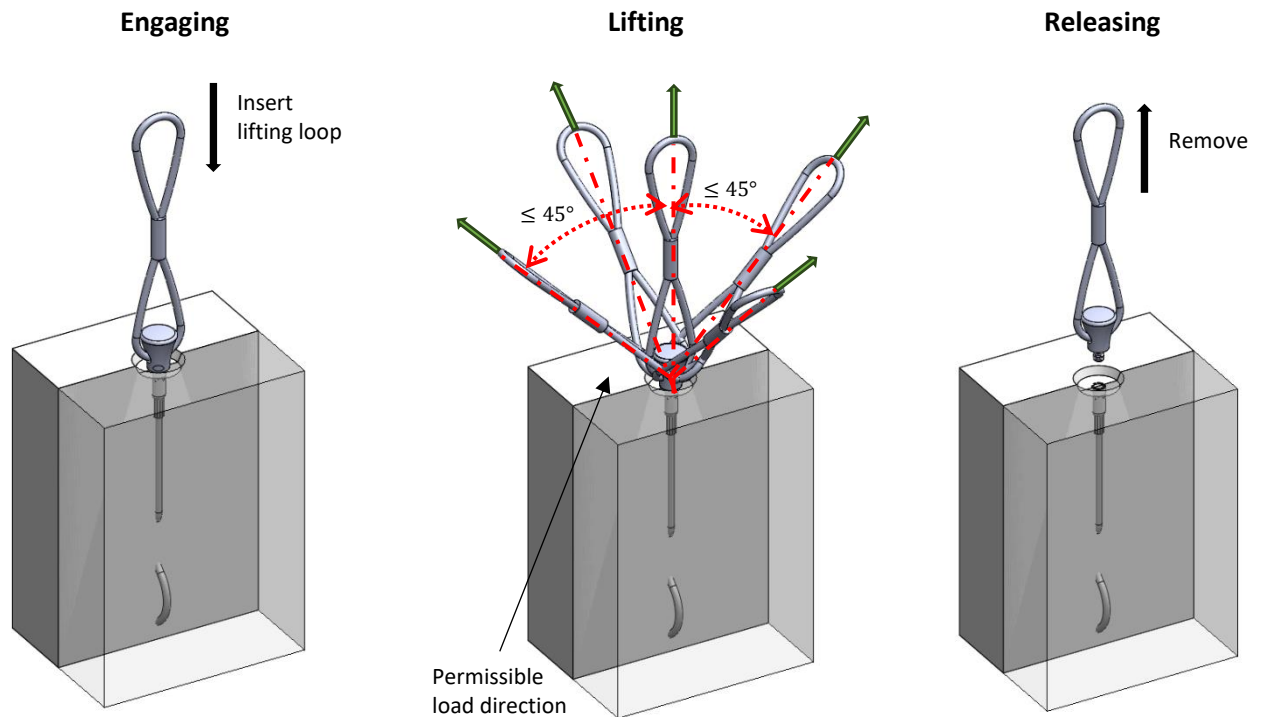

Verify that the transport anchor load capacity matches the lifting loop.
 Manually insert the lifting loop into the transport anchor.
 Once hand-tight, visually check that the lifting loop sits flush against the transport anchor. You can begin the lifting process.

Lifting loops are designed to handle loads in vertical and tilted orientations, provided the load limits of the transport anchors are not exceeded. The tilt lift should normally not exceed 45 degrees in all directions. When using a spreader beam, the tilt angle of the load can be reduced.

Manually disconnect the lifting loop by turning it out of the transport anchor.

Table 3 The connection between the lifting loop and transport anchor.

7 Safety factors for lifting systems:

For the calculations of the lifting system, the following safety factors shown Table 4 have been applied to ensure its reliability and safety. These factors, in accordance with the recommendation of EN13155, have been carefully selected as guidelines to ensure optimal safety during the system's operation.

Failure safety factors	
Steel failure of anchors	$SF_{Steel} = 3$
Concrete pull out failure	$SF_{concrete} = 2,5$
Failure in the lifting loop	$SF_{Link} = 4$

Table 4 Failure safety factors

8 General information

This section provides essential details on the Starcon transport anchor systems, offering clarity and guidance for safe and efficient usage.

8.1 Marking on the transport anchor

Each transport anchor is clearly labeled with its load capacity, length, and manufacturer's identification, ensuring easy and secure identification of the systems, even post-installation show on Figure 2.

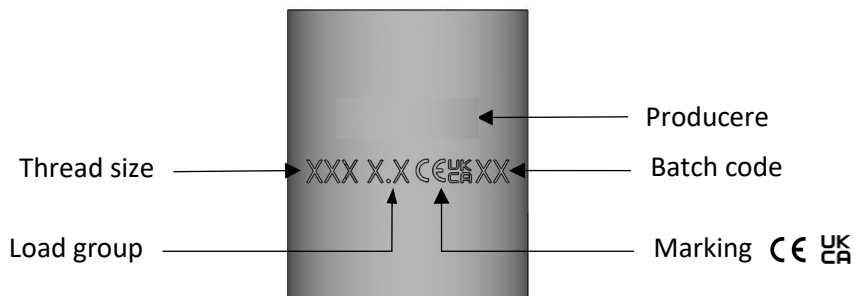

Figure 2 Marking on the cylinder of the transport anchor.

8.2 Guidelines for Transport anchor selection

When selecting transport anchors, it's essential to consider various factors to ensure safety and effectiveness. The tables provided contain crucial information such as maximum load capacities, edge distances, and installation values for different transport anchor types. Key points to consider:

- Weight of the precast element.
- The number of transport anchors.
- How the anchors are arranged.
- The load-bearing capacity of the transport anchors
- Sling handling angle.
- The diagonal pulls properties of the transport anchors.
- Environmental impact on the use.

8.3 Guidelines for installation

For the Starcon lifting anchor systems to be appropriately installed, it is imperative to ensure compliance with specific technical criteria and prerequisites:

- Adherence to load capacity specifications of the anchor.
- Maintaining appropriate edge spacing.
- Ensuring the concrete grade is suitable.
- Verifying alignment with the load direction.
- Additional reinforcement requirements.

8.4 Guideline for load capacity

Load capacity of an anchor relies on several factors:

- The strength of the concrete at the moment of lifting, as determined by a cube-test with dimensions of 15 × 15 × 15 cm.
- The length of the anchor.
- The spacing between the anchor and the edges, both axially and along the edge.
- The direction of the applied load.
- The arrangement of reinforcement within the concrete structure.

9 Design method

This section covers the design method for lifting operations as well as illustrations of various lifting techniques. It describes when the different types of lifts occur, including axial lifting, diagonal lifting, tilting, and rotation of elements. Additionally, the casting process is discussed, including the transfer of load to the concrete using the anchor base, and the importance of correctly placing formwork and anchors during casting to avoid errors and risks. Warnings are given regarding the correct size of formwork and the risk of errors with incorrect sizes, which can lead to potentially dangerous situations.

9.1 Illustration of lifting methods

Figure 3 shows a description of when the different types of lifts occur:

- **Axial pull:** occurs in the same direction as the pulling force and happens within the range of $0^\circ \leq \alpha \leq 10^\circ$.
- **Diagonal pull:** occurs when slings/chains are angled between $10^\circ \leq \alpha \leq 45^\circ$ relative to the lift.
- **Tilting:** occurs when the object needs to rotate around its COG on the long side of the element.
- **Turning:** occurs when the object needs to rotate around its COG on the long side of the element

Axial pull $\alpha: 0^\circ - 10^\circ$

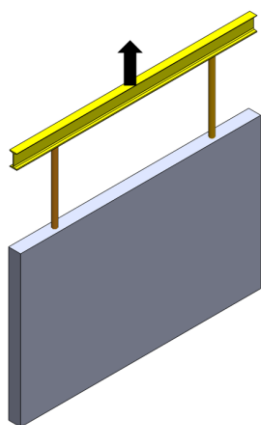

Diagonal pull $\alpha: 10^\circ - 45^\circ$

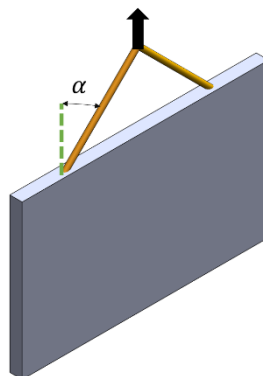

Tilting $\beta: 0^\circ - 90^\circ$

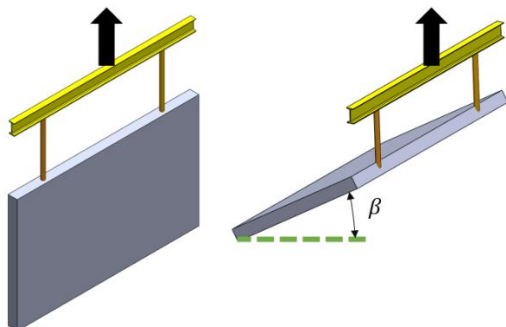

Turning pull $\gamma: 0^\circ - 45^\circ$

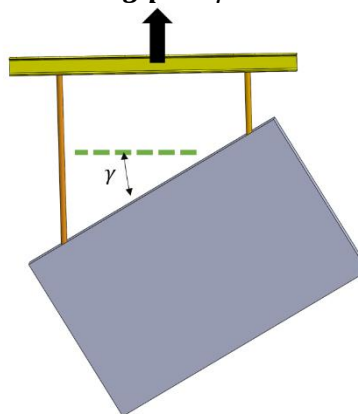

• Figure 3 Lifting methods.

9.2 Correct placement of nailing and transport anchors during casting

Caution: If the nailing plate is too small, it won't be compatible with the lifting equipment later. Conversely, if the recess block is too large, attaching the lifting equipment correctly will be impossible, increasing the risk of the lifting loop slipping out. This could lead to premature transport anchor failure and the subsequent collapse of the construction element. Always ensure the nailing size matches the identified appropriate size. Figure 4 illustrates the correct placement of the nailing plate in wet concrete to ensure optimal anchorage strength for the transport anchor.

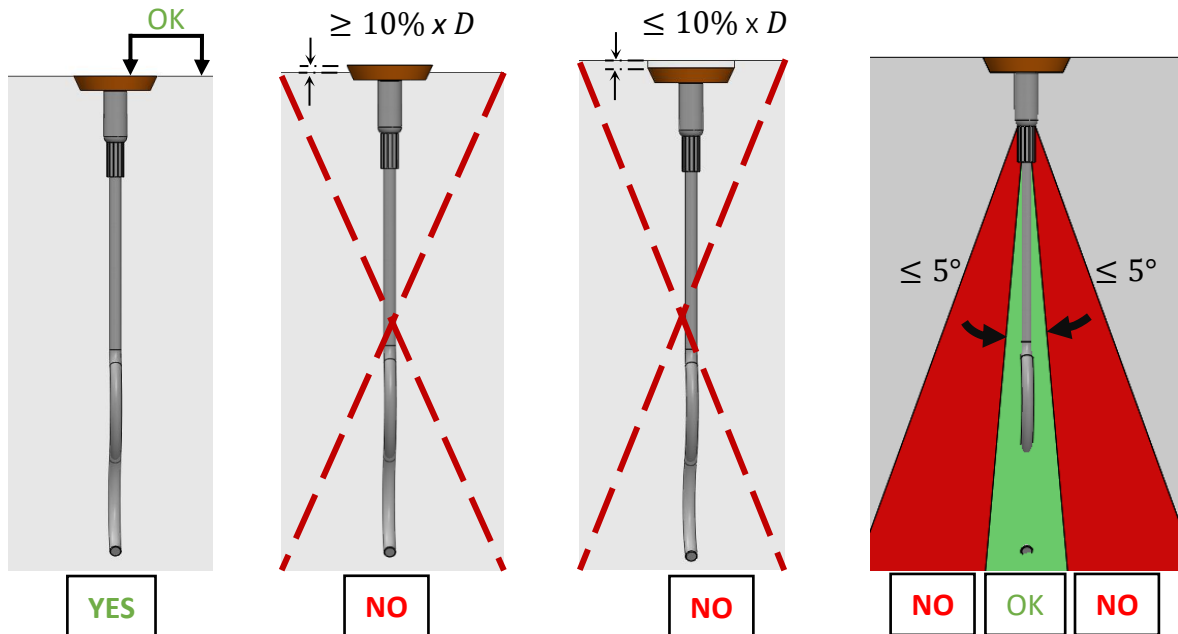

Figure 4 Correct placement of nailing plate.

9.3 Calculate load cases of removing from formwork and transport.

To ensure proper anchoring, each anchor must consider several factors: weight of the element, adhesion to the mold, shock load, sling angle, and the number and position of the anchors.

When lifting a concrete unit from a form, consider the adhesion factor between the concrete and the mold. For complex shapes, adhesion can increase anchor load, especially when concrete strength is at its lowest. Calculate the total weight of the elements in tons, including all equipment and accessories attached to the device.

9.3.1 Load case removing the formwork and transport of the element.

The tension force F_A in each the anchor:

1. Load case when removing the element from the formwork:
$$F_A = \frac{(F_Z + S \cdot Pa) \cdot F_s}{n}$$

2. Load Case during transport lifting of the element.
$$F_A = \frac{F_Z \cdot F_s \cdot \varphi_{dyn}}{n}$$

Where,

- F_Z : Weight of the concrete element in Tons (*ton*)
- S : Surface area of the mould in contact with the fresh concrete (m^2)
- Pa : Adhesion factor between the pouring box and concrete (See Table 6)
- F_s : Sling angle factor (See Table 5)
- n : Number of load-bearing anchors in the element.
- φ_{dyn} : Dynamic factor of the element under transport

9.3.2 Sling angle factor (F_S)

The illustration in Figure 5 provides a visual explanation of how to measure the sling angle. Referencing Table 5, you can find the sling factor corresponding to the measured angle.

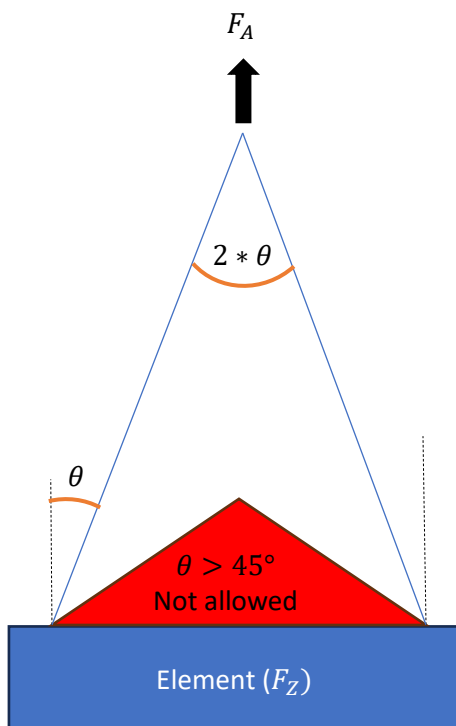

Figure 5 Sling angle factor illustration.

Sling angle degree (θ)	Sling factor (F_S)
0°	1
10°	1,02
20°	1,07
30°	1,16
45°	1,41

Table 5 Sling angle factor

9.3.3 Adhesion to formwork factors (Pa)

Adhesion factor between the pouring box and concrete is shown in Table 6.

Mould type	Adhesion ($\frac{ton}{m^2}$)
Lubricated steel form work	$Pa = 0,1$
Varnished timber formwork	$Pa = 0,2$
Rough formwork	$Pa = 0,3$

Table 6 Adhesion factor to formwork

9.3.4 Dynamic factors (φ_{dyn})

If the concrete unit is handled or transported by mechanical equipment, it is exposed to shock/impact from gripping and transport over uneven ground. This factor can increase the anchor load several times its own weight. The correct load can be determined by adding the dynamic factor φ_{dyn} shown in Table 7

Lifting condition	Dynamic load factor
Static crane, rope speed <90 m/min	1
Static crane, rope speed >90 m/min	1,3
Lift and transport with mobile crane on smooth ground	1,75
Lift and transport with mobile crane on uneven ground	2
Transport with forklift or excavator over uneven ground	3

Table 7 Dynamic factor

9.3.5 The number and position of lifting points

The effective load carried by each anchor is typically calculated by dividing the total weight by the number of load-bearing anchors. However, this calculation assumes equal load distribution among all anchors. If the load distribution is unequal, the load to be carried by each anchor should be determined using static calculations as shown in Figure 6.

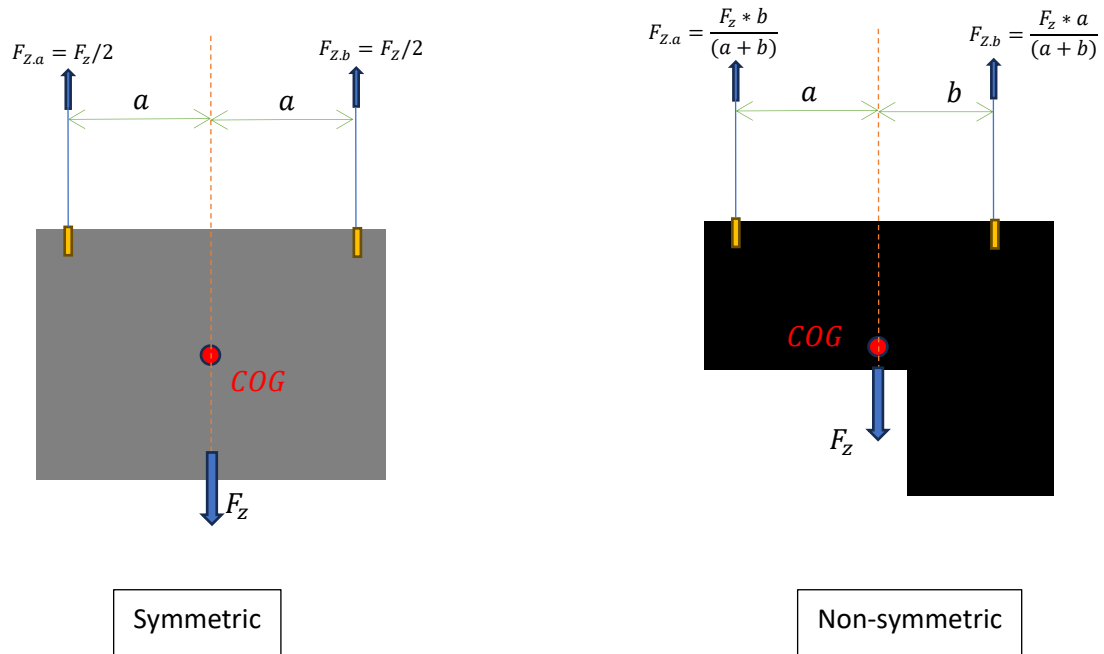

Figure 6 Calculation symmetric and non-symmetric loading element.

10 Recommend extra support for transport anchors with rebar long wave in concrete walls

Figure 7 explains how to correctly position the reinforcement mesh inside the element. It also demonstrates the proper placement of diagonal pull bars to effectively support the anchor and the opposite face during lifting or pulling operations, or additional reinforcement to support the anchor for tilting and turning. The supplementary reinforcement, classified as B500B according to DIN 488 standards as shown in the illustration.

- The diagonal pull reinforcement should be positioned as near as possible beneath the former and must be installed in full contact with the anchor.

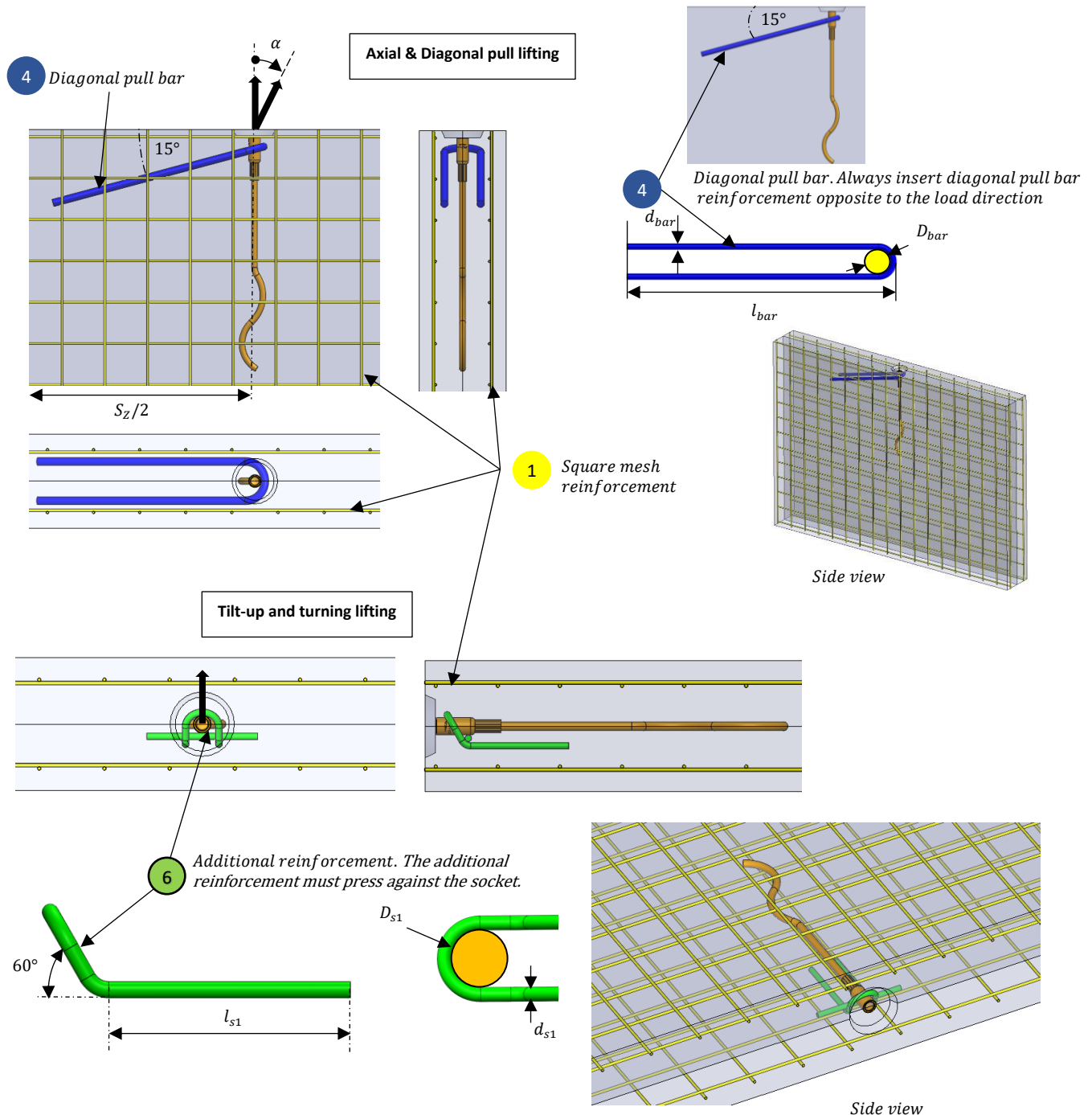

Figure 7 Reinforcement in the concrete wall.

Table 8 provides a detailed description of the correct placement of mesh and reinforcement within the concrete for each anchor type.

Load group anchor	Type anchor M x L mm	①	④			⑥		
		Square mesh reinforcement mm^2/m	Diagonal pull bar ① ②			Additional reinforcement		
			d_{bar} mm	D_{bar} mm	l_{bar} mm	d_{s1} mm	l_{s1} mm	D_{s1} mm
0.5S	M12x300	2 x 188	Ø 8	32	130	Ø 8	95	32
0.8S	M14x310	2 x 188	Ø 8	32	160	Ø 8	125	32
1.2S	M16x320	2 x 188	Ø 8	32	170	Ø 8	130	32
2S	M20x400	2 x 188	Ø 10	40	220	Ø 10	170	40
2.5S	M24x450	2 x 188	Ø 10	40	240	Ø 10	185	40
4S	M30x600	2 x 188	Ø 14	56	165	Ø 14	195	56
6.3S	M36x750	2 x 188	Ø 14	56	185	Ø 14	200	56
8S	M42x850	2 x 188	Ø 20	140	350	Ø 20	215	140
12.5S	M52x900	2 x 188	Ø 20	140	370	Ø 20	220	140

① To ascertain the necessity of diagonal load up reinforcement, refer to the load tables, particularly when $\alpha < 45^\circ$.
 ② To ensure proper reinforcement alignment, in cases where the precast element's dimensions limit the diagonal pull reinforcement length, it's permissible to bend the last 40% of the bar into a loop shape.

Disclaimer: The table serves solely as a guide. For accurate guidance and calculations, please contact www.Certex.dk.

Table 8 Reinforcement data for elements

11 Starcon transport anchors with standard reinforcement included.

This description aims to provide an understanding of the capacity of these anchors within structures with special reinforcements shown on Figure 8, including the following components, Reinforcement mesh, diagonal pull bars only if, $\alpha \leq 45^\circ$, and additional reinforcement. The table below provides insights that can contribute to an accurate evaluation of the suitability of lifting concrete elements in various scenarios.

- The angle at the lifting point must not exceed $\alpha > 45^\circ$. This is not allowed!

Reinforcement requirements see Table 8

- ① Reinforcement mesh
- ④ Diagonal pull bars, if $\alpha \leq 45^\circ$

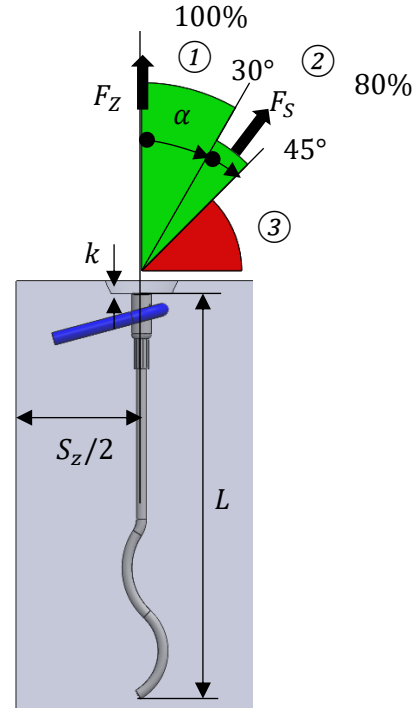
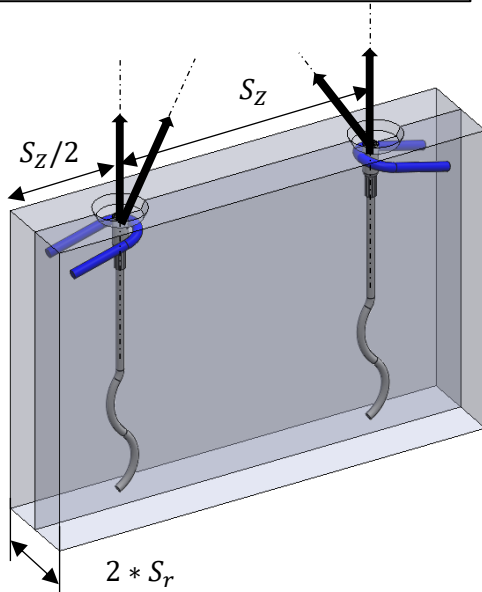

Axial & Diagonal pull lifting

Reinforcement requirements see Table 9

- ① Reinforcement mesh
- ⑥ Additional reinforcement

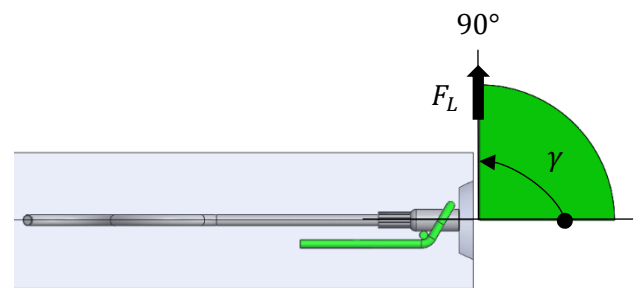
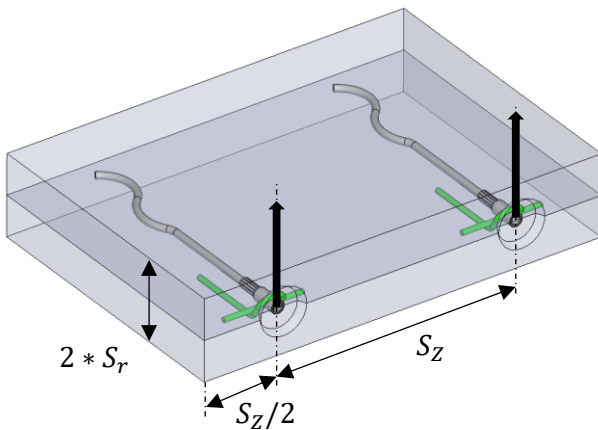

Tilt-up and turning lifting

- (1) Diagonal tension at $0^\circ \leq \alpha \leq 45^\circ$ without reinforcement is only allowed if:
 - Concrete compressive strength (σ_{ele}) is $\geq 15 \text{ N/mm}^2$ and 3 times the minimum wall thickness,
 - Concrete compressive strength (σ_{ele}) is $\geq 25 \text{ N/mm}^2$ and 2.5 times the minimum wall thickness,
- (2) For concrete strength with $\sigma_{ele} \geq 23 \text{ N/mm}^2$, the Safety Factor (F_S) equals the Load Factor (F_Z).
- (3) Diagonal tension with cable/chain spreading $\alpha > 45^\circ$ is not permitted.

Figure 8 Reinforcement requirements.

Lifting a Wall Element with standard reinforcement including Pull and tilt-up recruitment.

Table 9 provides information to assist in determining the appropriate anchors for lifting concrete elements under various loading conditions.

The following boundary conditions are utilized for the calculation:

- **1 anchor** symmetrically positioned to the center of gravity.
- **Dynamic factor** (site handling) $\Gamma_{dyn} = 1.3$
- **Formwork adhesion** is not considered.

Load group anchor	Type anchor M x L mm	Min. wall thickness $2 * S_r$ mm	Load capacity [Ton] with concrete strength σ_{ele}						Min. distance between anchors. S_z mm
			$\geq 15 N/mm^2$			$\geq 25 N/mm^2$			
			Axial Load	Diagonal Load $\alpha \leq 45^\circ$	Lateral load	Axial Load	Diagonal Load $\alpha \leq 45^\circ$	Lateral load	
			All lifting loop	All lifting loop	Alpha Goliath	All lifting loop	All lifting loop	Alpha Goliath	
0.5S	M12x300	60	0,78	1,02	0,27	0,86	1,26	0,35	280
0.8S	M14x310	60	0,86	1,1	0,27	1,1	1,41	0,35	360
1.2S	M16x320	80	1,26	1,26	0,31	1,65	1,57	0,39	360
2S	M20x400	100	2,35	1,57	0,78	2,67	1,96	1,02	500
2.5S	M24x450	100	3,14	1,81	0,78	3,53	2,2	1,02	600
4S	M30x600	140	4,47	3,45	1,73	5,1	4,47	2,28	700
6.3S	M36x750	140	7,06	3,85	1,73	7,85	5,1	2,28	800
8S	M42x850	160	9,58	4,79	1,73	10,2	6,12	2,28	1000
12.5S	M52x900	200	14,13	5,89	3,3	14,13	7,69	4,24	1200

σ_{ele} Stands for concrete element strength at time of lifting.
 Disclaimer: The table serves solely as a guideline. For accurate guidance and calculations, please contact www.Certex.dk.

Table 9 Standard reinforcement requirements.

12 General safety information when using the Starcon system.

General safety information when using the Starcon system.



- Ensure that the marking on the Starcon lifting unit always points in the direction of pull during lifting.
- The lifting machine must be approved to lift at least the maximum applied load + the weight of the Starcon lifting and handling system + any hoisting accessories.
- Lifting movements must be smooth; no sudden or abrupt changes in direction with the lifting machine should be made during a lifting operation, as this can lead to pendulum movements of the load, causing crushing hazards or dropping of the load.
- Where there is a risk of crushing between the load and objects, building parts, machinery, etc., the operator must not be in the danger zone.
- The operator's work area must be flat and free of obstacles that could pose a tripping hazard.
- When depositing the load, the operator must ensure this accepts on a flat and stable surface.
- Only when the load has been deposited and secured the Starcon lifting unit is completely unloaded may it be released and lifted free.
- Before each lift, ensure that both the Starcon lifting unit and the Starcon lifting anchor embedded in the concrete product are free from dirt that could reduce grip.
- Never insert arms or feet under a concrete product.
- Concrete products must never be dragged, only lifted.
- No modifications to the Starcon lifting and handling system may be made without written permission from the manufacturer.
- The operator must always ensure that the connection between the lifting machine and/or any hoisting accessories and the Starcon lifting unit is correct and secured against unintentional detachment.
- The operator must always ensure that the connection between the Starcon lifting unit and the Starcon lifting anchor is correct and secured against unintentional detachment.
- Keep a safe distance and never walk under a suspended load.
- Use gloves, safety shoes and other PPE when handling.
- Never use a Starcon lifting and handling system that has visible defects such as wear, deformations, rust damage, etc.
- Most anchors are designed to be easily handled during installation without the need for lifting equipment. However, some anchors may weigh more and should be handled using lifting equipment. Please refer to the order list for the accurate weight of each product.

12.1 Personal Protection

Always use gloves, a safety helmet, and safety shoes as a minimum requirement when operating the equipment. Keep hands and other body parts away from the lifting stand, lifting accessories, and the load during use.



12.2 Preparation of the product before use

12.2.1 Transport and Storage

Anchors should be transported and stored safely to prevent risks to personnel and nearby objects.

12.2.2 Unpacking

Remove the pallet and packaging protecting the anchors.

Cut the safety straps. The person unpacking should wear gloves, safety shoes, and safety glasses when cutting the straps.

12.2.3 Safe Disposal of Packaging Materials

All packaging used by Certex Denmark can be reused. Pallets and all wooden packaging can be reused or recycled.

All plastic, cardboard, and paper materials should be sent to the local recycling center.

If there are no local recycling facilities, the packaging should be returned to Certex Denmark for disposal at the customer's expense.

12.2.4 Preparatory Work Before Installation

After unpacking, visually inspect the anchors for any damage.

12.2.5 Installation and Assembly

The anchors are delivered ready for use.

12.2.6 Storage and Protection Between Periods of Normal Use

Inspect the anchors before each use and lift. Never use anchors or lifting accessories with visible defects such as wear, deformations, corrosion damage, etc.

Always store the lifting product indoors, in a dry and ventilated area.

12.2.7 Provision of Information (Users, Operators, Service Experts)

All operators or individuals within the danger zone must receive information on operating the anchors and must be trained by the supervisor, familiarizing themselves with the product and its use before lifting operations commence.

Operators must be trained in the use of the lifting bar and all its functions and positioned to have a clear view of the entire lifting operation.

12.2.8 Placement of Instruction

All user manuals should always be stored together with the lifting product.

13 Maintenance and inspection

- All maintenance must be performed when the Starcon lifting unit is unloaded.
- The Starcon lifting unit should be inspected and maintained to ensure it remains in proper condition during use.
- After each use, the Starcon lifting unit should be cleaned and inspected for any faults or deficiencies.
- If any faults are found, they must be rectified, or the Starcon lifting unit should be discarded.
- The Starcon lifting unit should always be stored in a dry and well-ventilated area.
- Any damaged, corroded, or worn-out Starcon lifting unit must be immediately taken out of service and marked not be used again.
- Equipment from Starcon should undergo at least one annual inspection by a qualified skilled person to inspect lifting equipment and cranes.

13.1 Maintenance Schedule



- Only original spare parts may be used, and they must be replaced by a trained individual.
- The annual inspection must be carried out by a qualified individual who has received the necessary training and certification for lifting equipment.
- All services must be documented, and the data must be stored.
- If there are any visual defects or if the labeling is not present on the lifting stand, the lifting stand must be marked as "out of service".

- B** Before use
- A** After use
- M** Monthly, or a maximum of 200 hours of usage.
- Y** Annually, or after a maximum of 2400 hours of use.

Inspection	B	A	M	Y
Perform a visual inspection to check for signs of overload, deformation, damage, wear, and corrosion.	X	X	X	X
The equipment must undergo inspection.			X	
Ensure that the equipment is ready and clearly labeled.	X			X
Inspection should be carried out by a qualified individual with a report prepared.				X

Table 10 Maintenance schedule

14 Disposal / Recycling

This section describes the end of use for the product.

- End of use / Disposal The lifting points shall be sorted / scrapped as general steel scrap.
- The Starcon lifting and handling system should be sorted and disposed of according to appropriate material categories, including metal, plastic, etc.
- Certex can assist you with disposal if required.

15 Product data of Lifting Socket with long-wavy Tail Bar

Figure 9 shows a measurement sketch for Lifting Socket with long-wavy Tail Bar with labels for the respective dimensions.

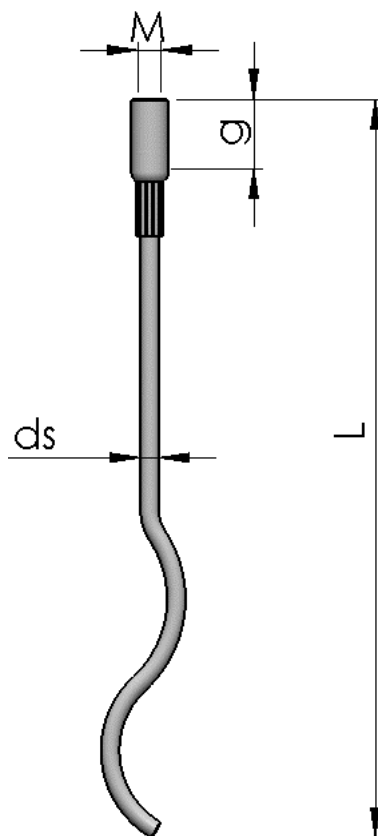

Figure 9 Transport anchor with rebar long wave sketch.

15.1 Technical data

Table 11 shows the dimensions of the various types of Lifting Socket with long-wavy Tail Bar.

Load group anchor	Rebar dia. d_s mm	Anchor length L mm	Thread M mm	Thead length g mm	Dia. nailing plate D_1 mm	Nail thickness K mm
0.5S	Ø 8	300	12	25	58	10
0.8S	Ø 10	310	14	25	58	10
1.2S	Ø 12	320	16	27	58	10
2S	Ø 14	400	20	35	58	10
2.5S	Ø 16	450	24	43	58	10
4S	Ø 20	600	20	56	58	10
6.3S	Ø 25	750	36	69	-	-
8S	Ø 38	850	42	80	-	-
12.5S	Ø 32	900	52	100	-	-

Table 11 Lifting Socket with long-wavy Tail Bar dimension.

16 Product data of Lifting loop

Figure 10 shows a measurement sketch for Lifting Loop.

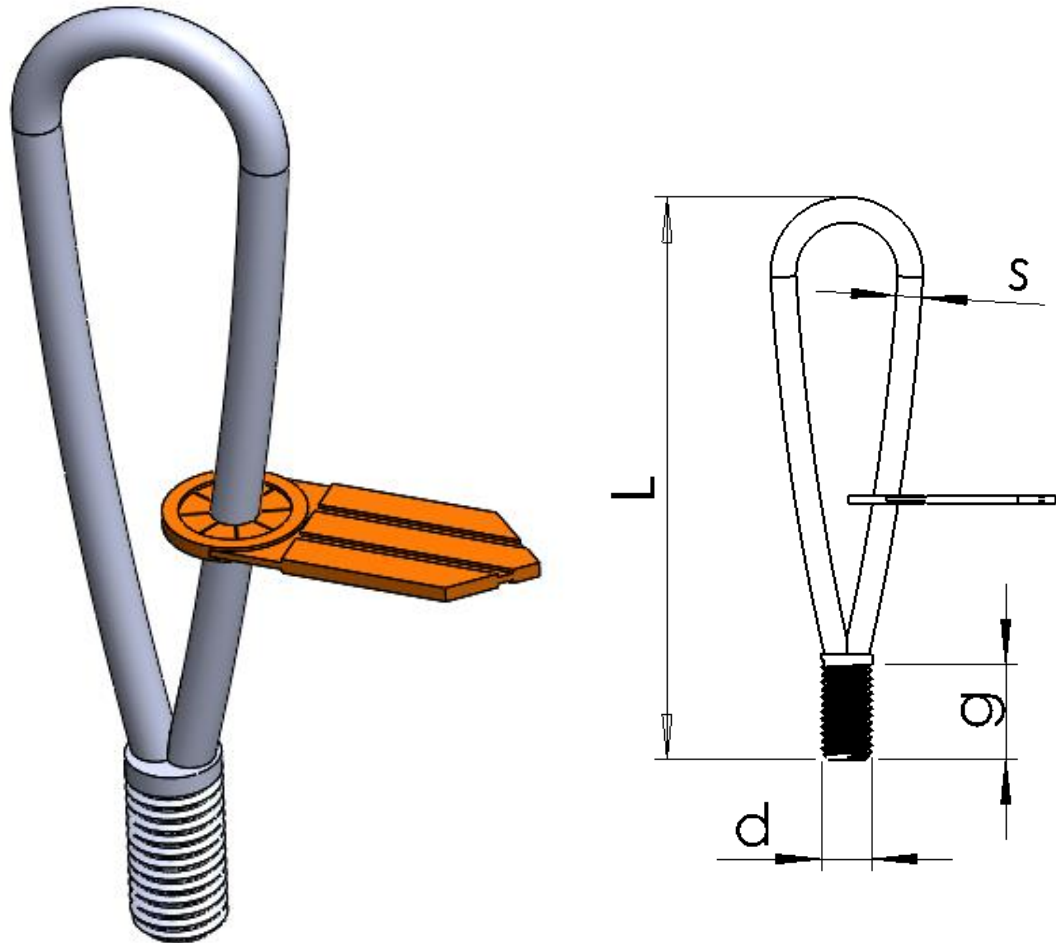

Figure 10 Lifting loop dimension sketch.

16.1 Technical data

Table 12 shows the dimensions of the various types of Lifting Loop

Load group lifting loop	Length of lifting loop L <i>mm</i>	Diameter of wire s <i>mm</i>	Thread d <i>mm</i>	Thread length g <i>mm</i>
0.5S	130	6	12	12,5
1.2S	170	8	16	14
2S	210	10	20	18
2.5S	260	12	24	27
4S	340	16	30	56

Table 12 Lifting loop dimension.

17 Product data of Alpha inclined pull lifting loop

Figure 11 shows a measurement sketch for ALPHA inclined Pull Lifting Loop

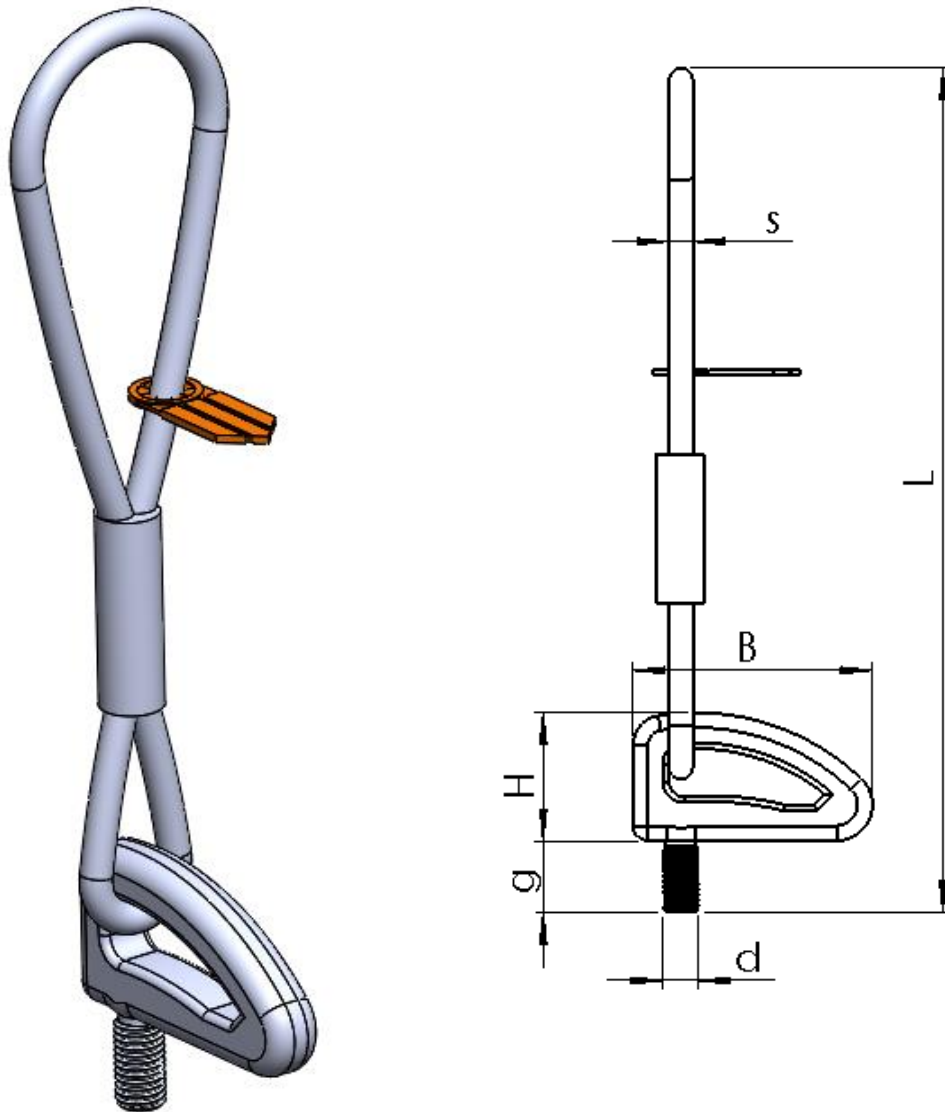

Figure 11 ALPHA inclined Pull Lifting Loop dimension sketch.

17.1 Technical data

Table 13 shows the dimensions of the various types of ALPHA inclined Pull Lifting Loop

Load group lifting loop	Length of lifting loop <i>L</i> mm	Diameter of wire <i>s</i> mm	Ring width <i>B</i> mm	Ring height <i>H</i> mm	Thread <i>d</i> mm	Thread length <i>g</i> mm
0.4S	260	8	55	42	10	22
0.5S	260	8	55	42	12	24
1.2S	320	10	55	42	16	28
2S	380	12	89	69	20	34
2.5S	430	14	89	69	24	39
4S	490	16	89	69	30	46

Table 13 ALPHA inclined Pull Lifting Loop dimension.

18 Product data of Goliath Lifting Loop 40.8

Figure 12 shows a measurement sketch for Goliath Lifting Loop 40.8

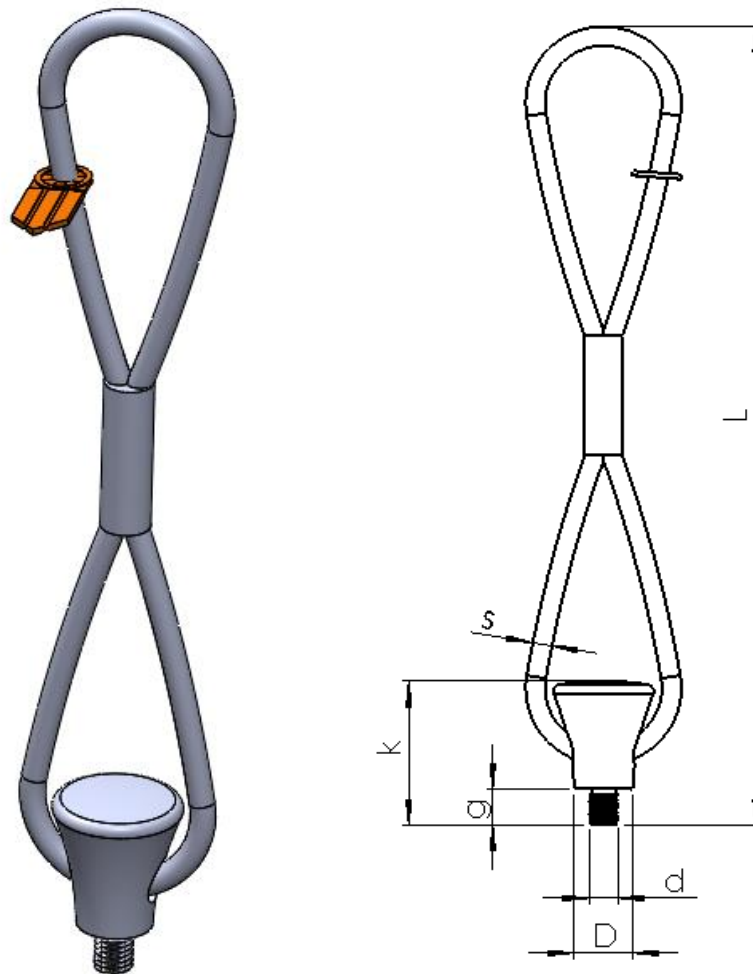

Figure 12 Goliath Lifting Loop 40.8 sketch.

18.1 Technical data

Table 14 shows the dimensions of the various types of Goliath Lifting Loop 40.8

Load group lifting loop	Length of lifting loop <i>L</i> mm	Diameter of wire <i>s</i> mm	Diameter of ring <i>D</i> mm	Ring height <i>k</i> mm	Thread <i>d</i> mm	Thread length <i>g</i> mm
0.4S	335	8	24	60	10	15
0.5S	335	8	24	60	12	15
1.2S	365	9	24	60	16	20
2S	470	12	44	102	20	25
2.5S	550	14	44	102	24	30
4S	590	16	44	102	30	35

Table 14 Goliath Lifting Loop 40.8 dimension.

19 Product data of nailing plates for transport anchors

Figure 13 shows a measurement sketch for the nailing plates.

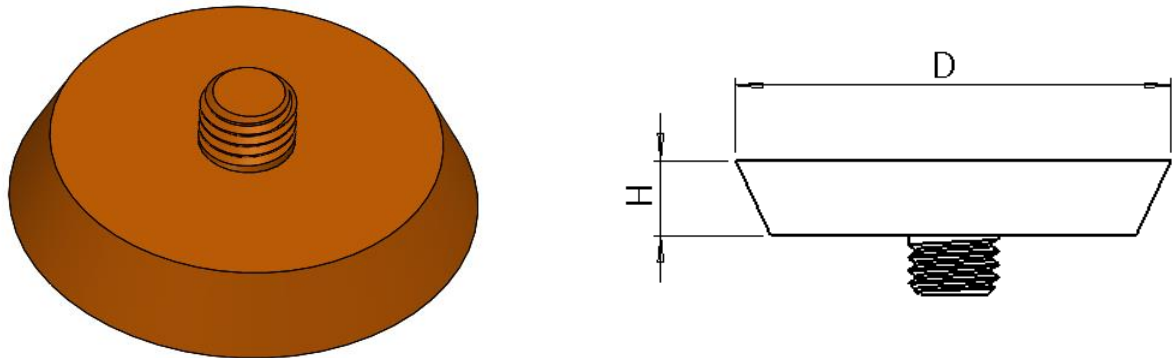

Figure 13 Nailing plates for transport anchors.

19.1 Technical data

Table 15 shows the dimensions of the various types of the nailing plate used for casting of the transport anchors.

Nailing plates Starcon Load group	D mm	H mm	Color
0.4S	58	10	Yellow
0.5S	58	10	Orange
1.2S	58	10	Red
2.0S	58	10	Light Green
2.5S	58	10	Black
4.0S	58	10	Dark Green

Table 15 Dimension of nailing plate for transport anchor.

20 EC – Declaration of Conformity of the Machinery

This certificate meets the requirements of the Directive 2006/42/EC Annex II.

Manufacturer and responsible for compiling the technical documentation:

Company:	CERTEX Danmark A/S	Tel. No.:	+45 74 54 14 37
Address:	Trekanten 6-8 6500 Vojens Denmark	E-mail:	info@certex.dk

The undersigned hereby declares that the below specified tool comply with the current safety and health rules and legislation within the European Union. If any changes are made on the tool without approval from the manufacturer, this Declaration no longer applies.

Description:	Lifting Socket with long-wavy Tail Bar
Drawing No.:	XXXXXXXXXXXXXXXXXX
Serial No.:	XXXXXX
Lifting Capacity:	WLL pr unit
Own Weight:	Kg pr unit

Is made in accordance with the following EC-directive;
2006/42/EC

The following standards have been used:
EN 13155+A2 : 2009

Date:

For CERTEX Danmark A/S

Our industries, products & services

At CERTEX Denmark, we are a secure and reliable total supplier and partner within lifting equipment. Below is an overview of the industries we service, our product range, and the services we offer."

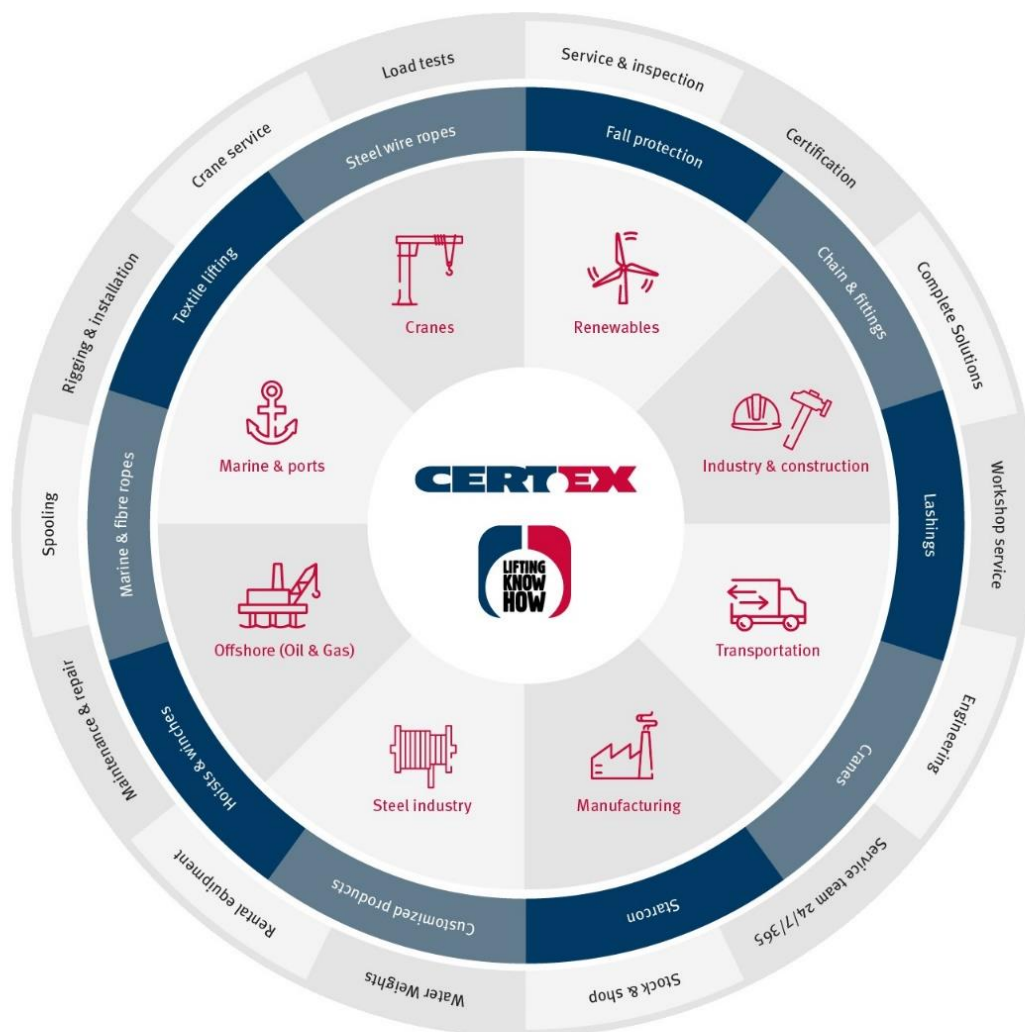

"

**Based on many years of experience
& know-how within lifting, load
tests & engineering, CERTEX
Denmark is your reliable partner &
supplier of steel wire, lifting
applications & related services."**