

# STARCON

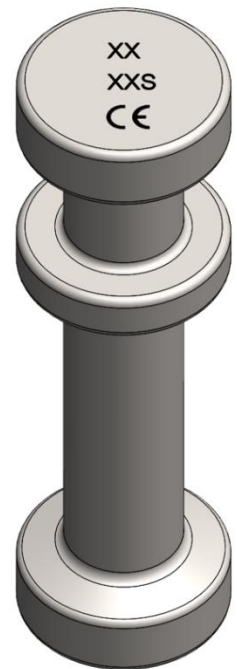

---

## STARCON

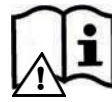

### Automation spherical anchor 2.5S to 7.5S

Lifting and handling systems for concrete elements.

User and design manual

## 1 Nomenclature

Symbol	Description	Unit
$\alpha$	Diagonal pull angle between sling and axial direction	°
$\beta$	Tilting angle between element and axial direction	°
$\gamma$	Turning angle between element and horizontal direction	°
°C	Temperature Celsius	°C
$\sigma_{ele}$	Concrete strength of the element at the time of lifting	MPa
<b>B</b>	Minimum plate thickness of a tile/slap/deck	mm
<b>COG</b>	Center of gravity	[–]
<b>D</b>	Anchor shaft diameter	mm
<b>d<sub>s</sub></b>	Diameter of the U-bar	mm
<b>d<sub>s1</sub></b>	Diameter diagonal pull bar	mm
<b>d<sub>s2</sub></b>	Diameter edge bar	mm
<b>d<sub>bar</sub></b>	Bending diameter of the diagonal pull bar	mm
<b>F<sub>S</sub></b>	Load in diagonal direction	N
<b>F<sub>Z</sub></b>	Load in axial direction	N
<b>L</b>	Length of the anchor	mm
<b>l<sub>1</sub></b>	Length u bar	mm
<b>l<sub>bar</sub></b>	Total link length of the diagonal pull bar	mm
<b>l<sub>s</sub></b>	Length of slot in link	mm
<b>o</b>	Distance between U-bars	mm
<b>S</b>	Load Groupe symbol (STARCON)	–
<b>S<sub>Z</sub></b>	Distance between anchors	mm
<b>WLL</b>	Working Load limit	tonne

Table 1 Nomenclature

## Starcon Precast Concrete Design & Lifting Manual

1	Nomenclature .....	1
2	Identification.....	2
3	Introduction Starcon Automation spherical anchor 2.5S to 7.5S. ....	3
4	Safety instructions before use .....	4
5	Advantages of the Starcon system. ....	4
6	Using the Starcon system.....	5
7	Safety factors for lifting systems: .....	6
8	General information .....	7
9	Design method.....	8
10	Recommend extra support for Automation spherical anchors in concrete walls .....	12
11	Starcon anchors with standard reinforcement including, U-bar, and edge reinforcement. ...	13
12	Load capacity of Automation spherical anchors in elements – tiles and decking .....	15
13	General safety information when using the Starcon system. ....	17
14	Maintenance and inspection .....	19
15	Disposal / Recycling .....	20
16	Product data of Automation spherical anchor .....	20
17	Product data of Starcon lifter universal.....	21
18	Product data of Starcon lifting eye flexible coupling.....	22
19	Product data of Starcon lifting eye standard coupling .....	23
20	Product data of Starcon former for spherical anchors. ....	24
21	EC – Declaration of Conformity of the Machinery.....	25

## 2 Identification

Table 2 provides insight into the revision number of this document. It facilitates tracking changes and ensuring version control for accurate referencing and updates.

Version	Responsible	Creator	Date	Comment
A	CERTEX Denmark	JLJ	10-02-2025	New documentation

Table 2 Revision table

## 3 Introduction Starcon Automation spherical anchor 2.5S to 7.5S.

**Read this instruction manual before using the spherical anchor. Incorrect use can cause injury or danger!**

*Safety is paramount when using lifting devices and equipment.*

*Only trained individuals should operate them as per national law.*

*Familiarize yourself with the instruction manual before using the Starcon lifting system to ensure safe operation.*

*Adhering to these guidelines reduces the risk of accidents.*

*Consult relevant national regulations as they may supersede these instructions.*

*All individuals involved with the equipment must read and understand this manual.*

*Always keep the manual with the product. Contact information is provided on the last page.*

*Contact Certex for assistance or clarification.*



### General description for the use of the anchor:

The Starcon Lifting and Handling System consists of three key components: Starcon Automation spherical anchor, Starcon Lifting eye, and Starcon former shown on Figure 1.

To ensure proper placement of the lifting unit in the finished concrete product, the head of the Starcon Lifting Anchor is assembled into a corresponding Starcon former before pouring. Once the concrete reaches a strength of at least 15 MPa, the former can be removed, and lifting can commence at the factory. At the installation site, lifting can only begin once the concrete has reached a strength of at least 25 MPa. Contact CERTEX DK for lower strength values. Lifting can be initiated by attaching the respectably rated lifting eye to the head of the Starcon Lifting Anchor.

The Starcon lifting anchors and systems use the guidelines described in the German guidelines VDI/BV-BS 6205 and Technical Report CEN/TR 15728, combined with EN 13155-2009. This ensures the highest level of safety when using our products.

**Material:** Steel.

**Surface treatment:** Untreated or hot dip galvanized (Corrosion class: C3, ISO 12944).

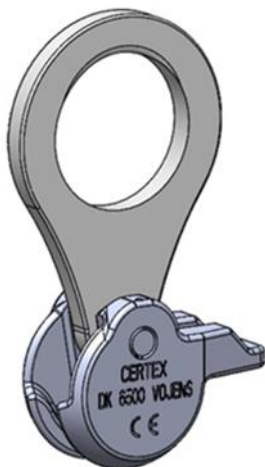

Lifting eye

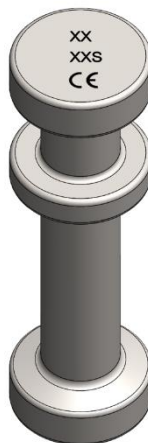

Automation spherical anchor

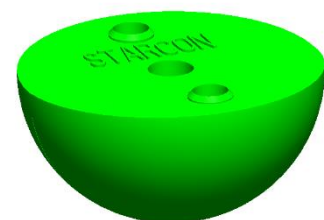

Starcon Former

Figure 1 Starcon lifting system.

### 4 Safety instructions before use

- The Starcon lifting anchor must only be installed in a Starcon former of the same rating.
- Starcon lifting anchors that are exposed of corrosion, or damaged must not be used.
- The Starcon lifting anchor must only be hoisted by a lifting unit of the same size.
- The Starcon lifting and handling system must not be used to lift more than the specified load.
- The Starcon lifting and handling system must not be used for personnel lifting.
- The Starcon products are designed for one-time lifting only.
- The Starcon lifting system must only be used by skilled, trained employees.
- A lifting accessory used with the lifting eye must be correctly marked and approved for lifting.
- Before use, check the weather conditions. Never operate the system outdoors if there is a likelihood of lightning in the area and avoid use in extreme weather conditions such as storms, heavy rain, or snowing.
- The concrete safety factor assumes a factory production control complying with EN13369. If these requirements are not fulfilled, a safety factor of  $\gamma = 2,5$  shall be used.
- All relevant concrete failure modes shall be verified by the pre casting manufacturer of the concrete elements; the different failure modes and verification methods are specified in EN13155 (Annex H).

### 5 Advantages of the Starcon system.

The Starcon system offers immediate assembly and release options for the lifting eye, enabling precast concrete units to be handled quickly, safely, and economically, as shown on Figure 2. A self-locking lifting eye prevents accidental release. With the Starcon systems, time-consuming screw connections and wires prone to wear are avoided. Due to the lifting eyes' high robustness, they can be used reliably for many years.

The Starcon system is available in load group 1.3S to 32S. The lifting eye rotates freely around the anchor's axis, and the unique geometry of the system means the anchors can bear their full load even if they pull perpendicular to the anchor's axis.

The system's efficiency has been proven through many years of successful use and numerous laboratory tests. Components are regularly tested during production and clearly marked with the maximum load. The lifting eye is individually tested and comes with a traceability batch code.

#### 5.1 Note

The information in this manual is for guidance only, and the use of the manual does not in any way exempt the manufacturer from ensuring that the chosen lifting system is suitable for the intended purpose. The information and data listed in this manual only refer to original Starcon products supplied by CERTEX DANMARK A/S.



Figure 2 The connection between the Starcon lifting eye and the Starcon Anchor is fast and easy.

## 6 Using the Starcon system

The Starcon system comprises a wide range of anchors in a load group from 1.3S to 5S per anchor with various lengths. The principle for using the system is the same for the entire range. The Starcon system consists of the following three main components:

### 6.1 Starcon Anchor

The Starcon anchor is a steel component for embedding with a specially designed foot for solid anchoring in hardened concrete. The head of the Starcon anchor, which is cylindrical in shape, connects to a Starcon lifting eye for lifting purposes. Starcon anchors are clearly labeled with sizes (e.g., 2.5S) and are available in different lengths. They undergo sample testing for defects, dimensional deviations, and tensile strength with a safety factor of minimum 3:1 for metallic failure.

### 6.2 Starcon Former

The former are semi-spherical soft PVC components or steel used for embedding an anchor in wet concrete. The anchor head is placed in the former, which can then be bolted to the formwork. After the unit is cast and hardened, the former is removed, revealing the anchor head seated in a semi-spherical depression in the concrete. Each former can be used for multiple castings if cleaned and lubricated after each use.

*The formers are also available in a steel version, with rubber material.*

### 6.3 Starcon Lifting Eye

The Starcon lifting eye is a specially designed component with a ball-shaped claw that grips under the head of the Starcon anchor. Starcon lifting eyes are tested to twice the allowable load, and all test results are recorded. Each Starcon lifting eye is marked with article number, identification number, and maximum working load with a safety factor of 4:1. A certificate is issued for each delivery.

An additional safety measure is that the Starcon system is available in several non-compatible load groups. It is not possible to incorrectly assemble components from different load groups, thus avoiding failure of the lifting arrangement.

## 6.4 Lifting eye assembly instructions.

Align the spherical Head Lifting eye above the anchor head, opening downwards, and turn the lip to secure it. The eye prevents accidental uncoupling under load. Always ensure the lip points towards the tension direction during lifting. Release the load, then turn the lip back to uncouple. The instruction is shown and explained in Table 3.

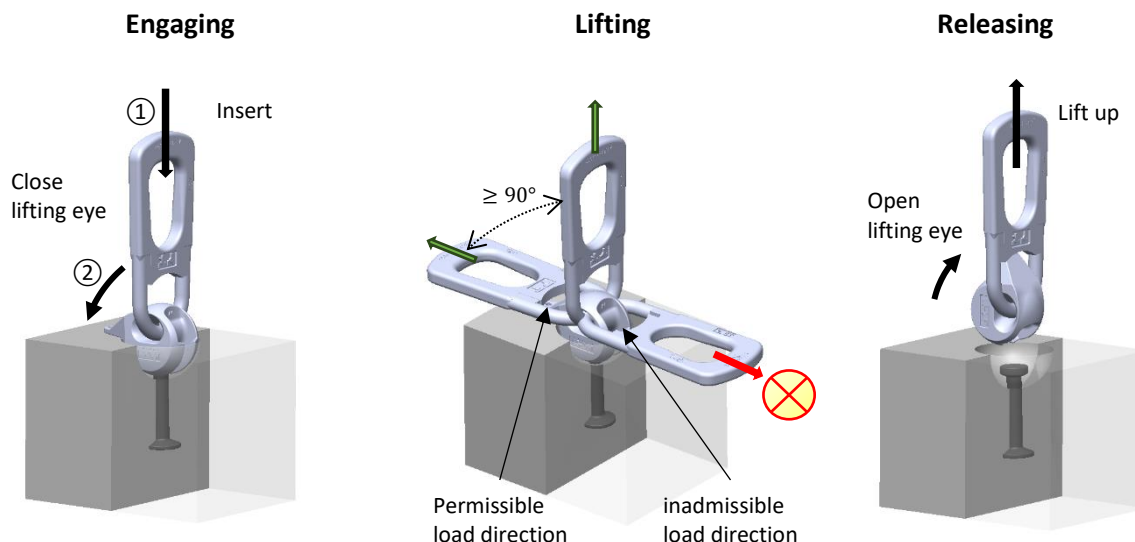

Verify the anchor's load capacity matches the lifting link.

- ① To engage, position the ball with the opening facing down over the anchor.
- ② Then rotate the tongue away from the lifting link towards the concrete surface. The lifting link is now secured and ready for use.

The design ensures the eye stays secure under load. Always align the lip with the tension direction when lifting. It supports axial, diagonal. When turning elements, the lip must point towards the tension.

Manually release the load and turn the lip back to disconnect to enable the removal of anchor

Table 3 The connection between the lifting eye and spherical anchor is fast and easy.

## 7 Safety factors for lifting systems:

For the calculations of the lifting system, the following safety factors shown Table 4 have been applied to ensure its reliability and safety. These factors, in accordance with the recommendation of EN13155, have been carefully selected as guidelines to ensure optimal safety during the system's operation.

Failure safety factors	
Steel failure of anchors	$SF_{Steel} = 3$
Concrete pull out failure	$SF_{concrete} = 2,5$
Failure in the lifting- eye	$SF_{Link} = 4$

Table 4 Failure safety factors

## 8 General information

This section provides essential details on the Starcon lifting anchor systems, offering clarity and guidance for safe and efficient usage.

### 8.1 Marking on the anchor

Each anchor is clearly labeled with its load capacity, length, and manufacturer's identification, ensuring easy and secure identification of the systems, even post-installation show on Figure 3.

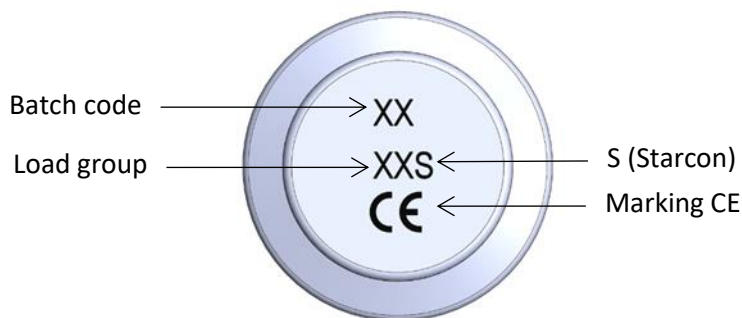

Figure 3 Marking on top of the Automation spherical anchor.

### 8.2 Guidelines for Anchor Selection

When selecting anchors, it's essential to consider various factors to ensure safety and effectiveness. Tables provided contain crucial information such as maximum load capacities, edge distances, and installation values for different anchor types. Key points to consider:

- Weight of the precast element.
- The number of anchors.
- How the anchors are arranged.
- The load-bearing capacity of the anchors
- Sling handling angle.
- Dynamic factor.
- The diagonal pull properties of the anchors.
- Environmental impact at the use.

### 8.3 Guidelines for installation

For the Starcon lifting anchor systems to be appropriately installed, it is imperative to ensure compliance with specific technical criteria and prerequisites:

- Adherence to load capacity specifications of the anchor.
- Maintaining appropriate edge spacing.
- Ensuring the concrete grade is suitable.
- Verifying alignment with the load direction.
- Additional reinforcement requirements.

### 8.4 Guideline for load capacity

Load capacity of an anchor relies on several factors:

- The strength of the concrete at the moment of lifting, as determined by a cube-test with dimensions of 15 × 15 × 15 cm.
- The length of the anchor.
- The spacing between the anchor and the edges, both axially and along the edge.
- The direction of the applied load.
- The arrangement of reinforcement within the concrete structure.



## 9 Design method

This section covers the design method for lifting operations as well as illustrations of various lifting techniques. It describes when the different types of lifts occur, including axial lifting, diagonal lifting, tilting, and rotation of elements. Additionally, the casting process is discussed, including the transfer of load to the concrete using the anchor base, and the importance of correctly placing formwork and anchors during casting to avoid errors and risks. Warnings are given regarding the correct size of formwork and the risk of errors with incorrect sizes, which can lead to potentially dangerous situations.

### 9.1 Illustration of lifting methods

Figure 4 shows a description of when the different types of lifts occur:

- **Axial pull:** occurs in the same direction as the pulling force and happens within the range of  $0^\circ \leq \alpha \leq 10^\circ$ .
- **Diagonal pull:** occurs when slings/chains are angled between  $10^\circ \leq \alpha \leq 60^\circ$  relative to the lift.
- **Tilting:** occurs when the object needs to rotate around its COG on the short side of the element.
- **Turning:** occurs when the object needs to rotate around its COG on the long side of the element.

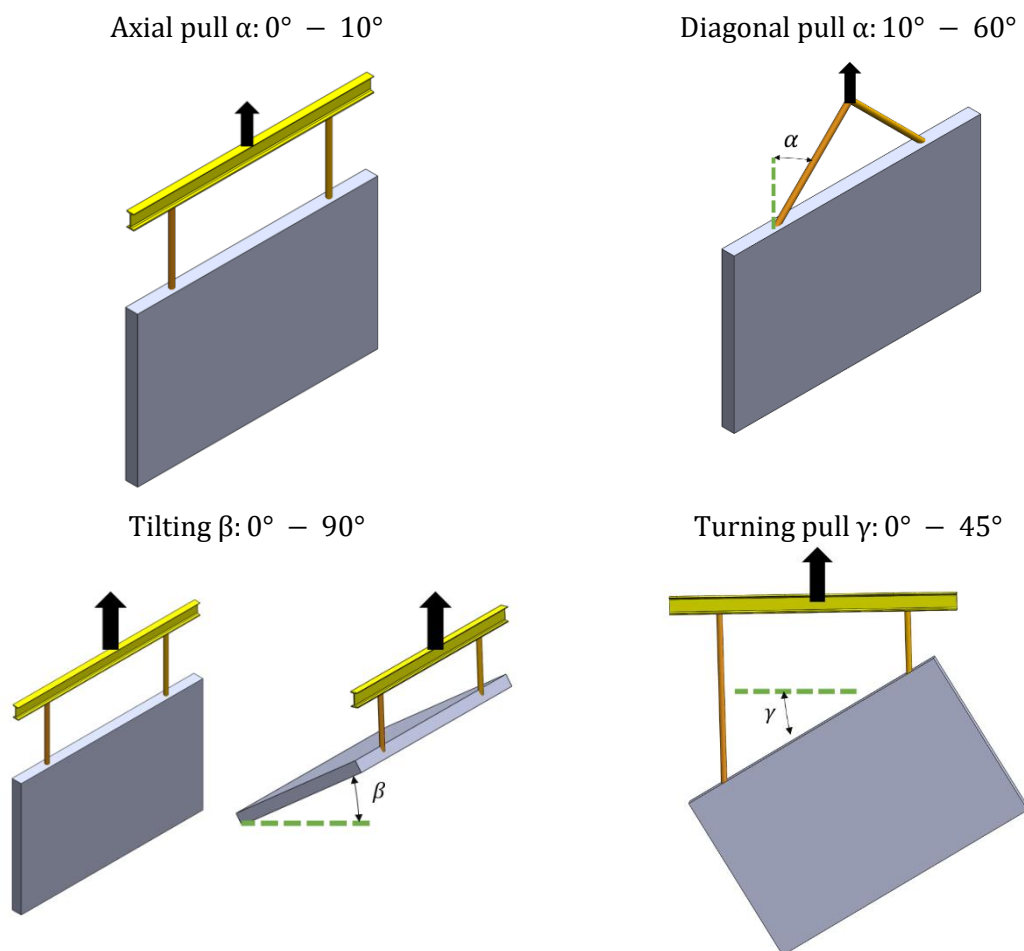

Figure 4 Lifting methods.

## 9.2 Load Transfer with Anchor Casting

Load transfer to the concrete is made easier by the anchor foot, which means it can handle heavy loads even with short anchors shown on Figure 5. However, with very thin elements, these concentrated loads can cause lateral spalling because of the strong pulling forces. The concrete must withstand a minimum resistance of 2.5 units before experiencing structural failure.

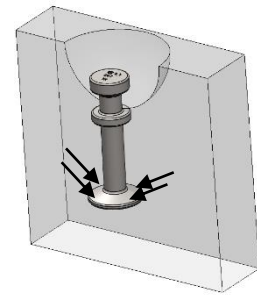

Figure 5 Load transfer.

### 9.2.1 Correct placement of former and anchors during casting.

Caution: If the form is too small, it won't be compatible with the lifting equipment later. Conversely, if the recess block is too large, attaching the lifting equipment correctly will be impossible, increasing the risk of the lifting eye slipping out. This could lead to premature anchor failure and the subsequent collapse of the construction element. Always ensure the form size matches the identified appropriate size. Figure 6 illustrates the correct placement of the former in wet concrete to ensure optimal anchorage strength for the anchor.

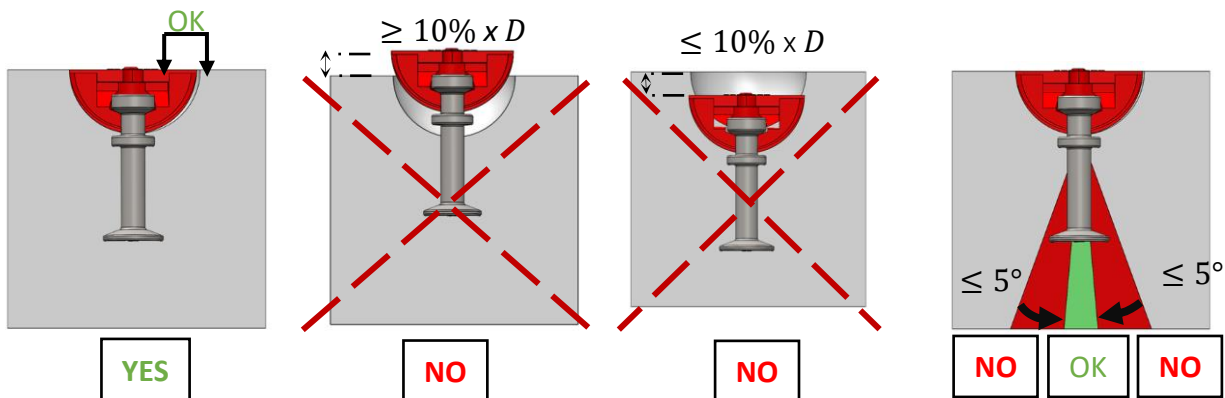

Figure 6 Correct placement of former.

## 9.3 Calculate load cases of removing from formwork and transport.

To ensure proper anchoring, each anchor must consider several factors: weight of the element, adhesion to the form, shock load, sling angle, and the number and position of the anchors.

When lifting a concrete unit from a form, consider the adhesion factor between the concrete and the form. For complex shapes, adhesion can increase anchor load, especially when concrete strength is at its lowest. Calculate the total weight of the elements in tons, including all equipment and accessories attached to the device.

### 9.3.1 Load case removing the formwork and transport of the element.

The tension force  $F_A$  in each the anchor:

1. Load case when removing the element from the formwork: 
$$F_A = \frac{(F_Z + S * Pa) * F_S}{n}$$

2. Load Case during transport lifting of the element. 
$$F_A = \frac{F_Z * F_S * \varphi_{dyn}}{n}$$

Where,

- $F_Z$ : Weight of the concrete element in tonne
- $S$ : Surface area of the mould in contact with the fresh concrete ( $m^2$ )
- $Pa$ : Adhesion factor between the form and concrete (See Table 6)
- $F_S$ : Sling angle factor (See Table 5)
- $n$ : Number of load-bearing anchors in the element.
- $\varphi_{dyn}$ : Dynamic factor of the element under transport

### 9.3.2 Sling angle factor ( $F_S$ )

The illustration in Figure 7 provides a visual explanation of how to measure the sling angle. Referencing Table 5, you can find the sling factor corresponding to the measured angle.

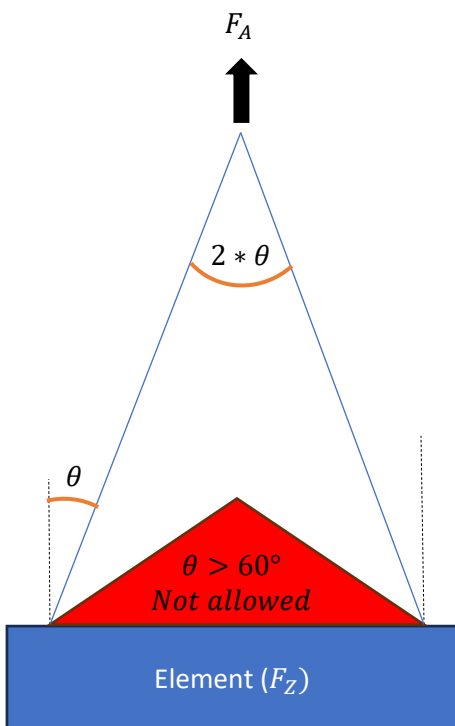

Figure 7 Sling angle factor illustration.

Sling angle degree ( $\theta$ )	Sling factor ( $F_S$ )
0°	1
10°	1,02
20°	1,07
30°	1,16
45°	1,41
60°	2

Table 5 Sling angle factor

### 9.3.3 Adhesion to formwork factors (Pa)

Adhesion factor between the pouring box and concrete is shown in Table 6.

Mould type	Adhesion ( $\frac{\text{tonne}}{\text{m}^2}$ )
Lubricated steel form work	Pa = 0,1
Varnished timber formwork	Pa = 0,2
Rough formwork	Pa = 0,3

Table 6 Adhesion factor to formwork

### 9.3.4 Dynamic factors ( $\varphi_{\text{dyn}}$ )

If the concrete unit is handled or transported by mechanical equipment, it is exposed to shock/impact from gripping and transport over uneven ground. This factor can increase the anchor load several times its own weight. The correct load can be determined by adding the dynamic factor  $\varphi_{\text{dyn}}$  shown in Table 7

Lifting condition	Dynamic load factor
Static crane, rope speed <90 m/min	1
Static crane, rope speed >90 m/min	1,3
Lift and transport with mobile crane on smooth ground	1,75
Lift and transport with mobile crane on uneven ground	2
Transport with forklift or excavator over uneven ground	3

Table 7 Dynamic factor

### 9.3.5 The number and position of lifting points

The effective load carried by each anchor is typically calculated by dividing the total weight by the number of load-bearing anchors. However, this calculation assumes equal load distribution among all anchors. If the load distribution is unequal, the load to be carried by each anchor should be determined using static calculations as shown in Figure 8.

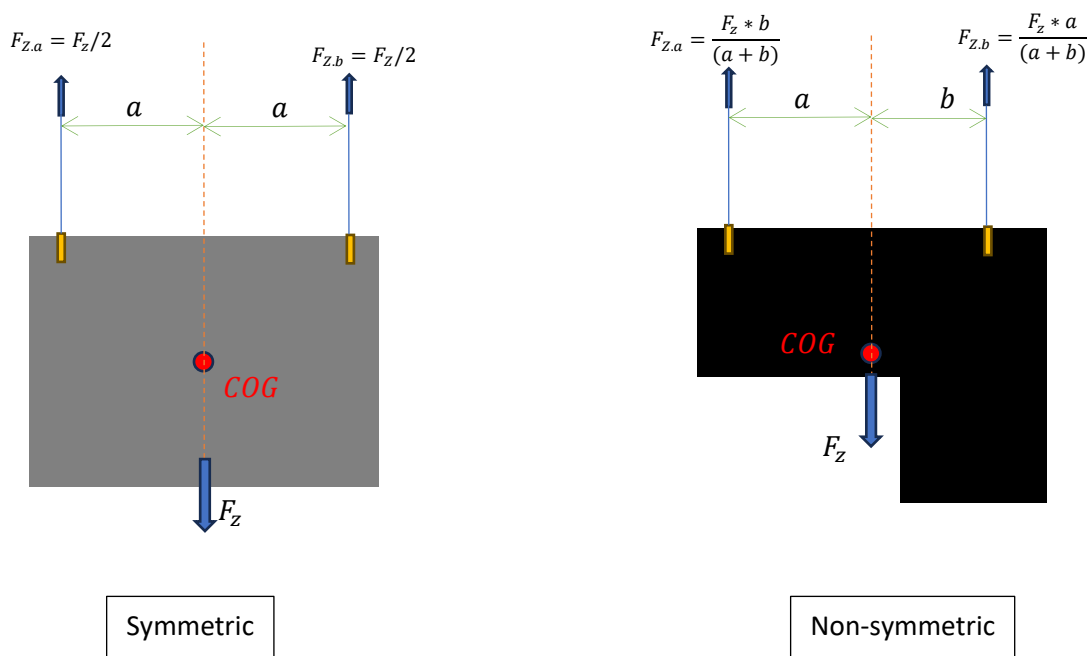

Figure 8 Calculation symmetric and non-symmetric loading element.

### 10 Recommend extra support for Automation spherical anchors in concrete walls

Figure 9 explains how to correctly position the reinforcement mesh inside the element. It also demonstrates the proper placement of diagonal pull bars to effectively support the anchor and the opposite face during lifting or pulling operations. All reinforcement must be classified as B500B according to DIN 488 or equivalent standards. The reinforcement pull bar should be bent at a  $30^\circ \pm 2^\circ$  angle, as shown in the illustration, to give the optimal strength and embedment.

- The diagonal pull reinforcement should be positioned as near as possible beneath the former and must be installed in full contact with the anchor.

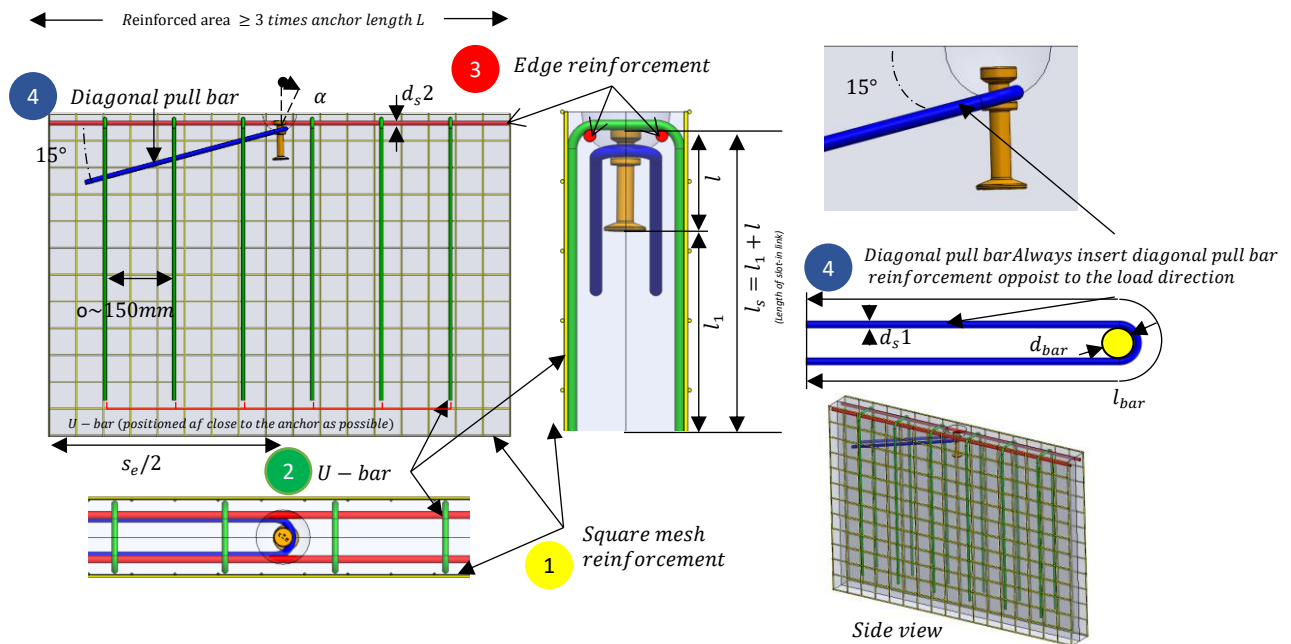

Figure 9 Reinforcement in the concrete wall.

Table 8 provides a detailed description of the correct placement of mesh and reinforcement within the concrete for each anchor type.

Load group anchor	① Square mesh reinforcement			② U-Bar						③ Edge reinforcement both sides	④ Diagonal pull bar			
	No. of net	Wire dia. mm	Dist. mm	For pull $\leq 30^\circ$ [ $\alpha$ ]			For pull $> 30^\circ$ [ $\alpha$ ]				$d_s 2$ mm	$d_s 1$ mm	$d_{bar}$ mm	$l_{bar}$ mm
				pcs.	$d_s$ mm	$l_1$ mm	pcs.	$d_s$ mm	$l_1$ mm					
2.5S	2	Ø8	100	≥ 2	Ø8	610	≥ 4	Ø8	610	Ø10	Ø10	25	1500	
5.0S	2	Ø10	140	≥ 2	Ø10	720	≥ 4	Ø10	720	Ø12	Ø14	35	2000	
7.5S	2	Ø10	160	≥ 4	Ø10	720	≥ 6	Ø10	720	Ø12	Ø16	40	2300	

① To ensure optimal spacing, the utilization of concise anchors alongside a substantial minimum quantity of u-bars is mandated, with a requirement for intervals not exceeding 150 mm.

② To determine the length of the link ( $l_s$ ), add the length of the anchor ( $l$ ) to the corresponding value ( $l_1$ ) obtained from the provided table.

③ When dealing with extremely thin panels ( $2 \times e \leq 70$ ), the square mesh may be utilized in a single layer (for instance,  $2 \times 66 \text{ mm}^2/\text{m}$  is needed, while  $1 \times 132 \text{ mm}^2/\text{m}$  should be placed centrally). In such instances, diagonal placement of the u-bars is permissible; however, edge reinforcement must be positioned on both sides of the anchor.

④ The U-bars need to be uniformly positioned on both sides of the anchor within a region 2.5 times the length of the anchor, with the initial U-bar on each side placed as near as feasible to the recess former.

⑤ To ascertain the necessity of diagonal pull reinforcement, refer to the load tables, particularly when  $\alpha > 30^\circ$ .

⑥ To ensure proper reinforcement alignment, in cases where the precast element's dimensions limit the diagonal pull reinforcement length, it's permissible to bend the last 40% of the bar into a loop shape.

**Disclaimer: The table serves solely as a guideline. For accurate guidance and calculations, please contact [www.Certex.dk](http://www.Certex.dk).**

Table 8 Reinforcement data for elements

## 11 Starcon anchors with standard reinforcement including, U-bar, and edge reinforcement.

This description aims to provide an understanding of the capacity of these anchors within structures with special reinforcements shown on Figure 10, including the following components, Reinforcement mesh, U-Bar, edge reinforcement and diagonal pull bars only if,  $\alpha > 30^\circ$ . The table below provides insights that can contribute to an accurate evaluation of the suitability of lifting concrete elements in various scenarios.

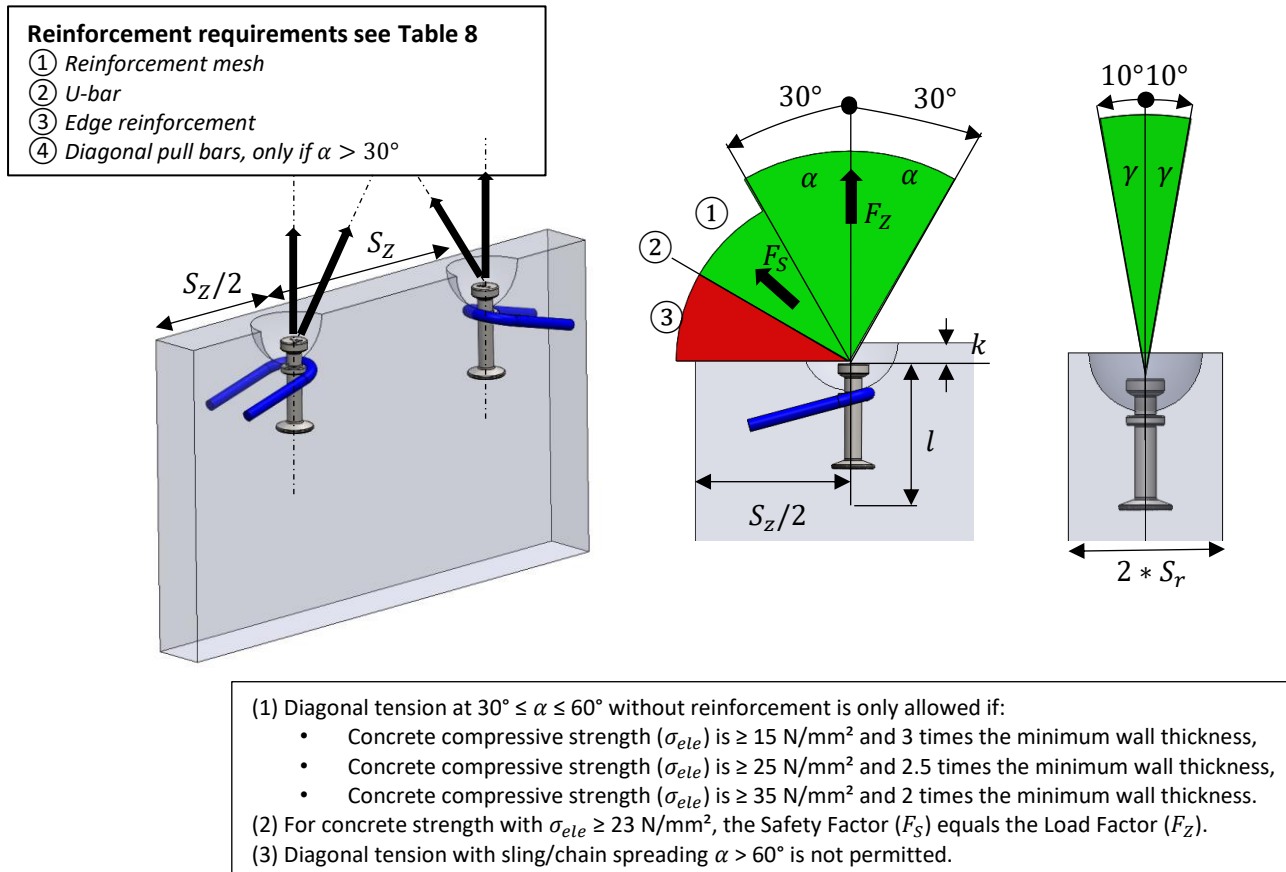

Figure 10 Reinforcement requirements.

### Lifting a Wall Element

Table 9 provides information to assist in determining the appropriate anchors for lifting concrete elements under various loading conditions. The table considers both diagonal tensions up to 45° ( $\alpha$ ) and transverse tension up to 10° ( $\gamma$ ).

The following boundary conditions are utilized for the calculation:

- **1 anchor** symmetrically positioned to the center of gravity.
- **Dynamic factor** (site handling)  $\Gamma_{dyn} = 1.3$
- **Formwork adhesion** is not considered.

Load group	Anchor length.  L  mm	Min. wall thickness  $2 * S_r$  mm	Load capacity [Ton] with concrete strength $\sigma_{ele}$				Min. distance between anchors.  $S_z$  mm
			Diagonal Pull $\alpha < 45^\circ$ $\gamma < 10^\circ$  15 N/mm2	Axial Pull $\alpha < 10^\circ$ $\gamma < 10^\circ$  25 N/mm2	Diagonal Pull $\alpha < 45^\circ$ $\gamma < 10^\circ$  25 N/mm2	Diagonal Pull $\alpha < 45^\circ$ $\gamma < 10^\circ$  35 N/mm2	
2.5S	55	160	<b>1,09</b>	<b>2,03</b>	<b>1,46</b>	<b>1,59</b>	380
	68		<b>1,12</b>	<b>2,03</b>	<b>1,46</b>	<b>1,59</b>	
	85		<b>1,16</b>	<b>2,03</b>	<b>1,46</b>	<b>1,59</b>	
5S	95	200	<b>2,10</b>	<b>3,93</b>	<b>2,82</b>	<b>3,16</b>	380
	120		<b>2,19</b>	<b>4,01</b>	<b>2,88</b>	<b>3,16</b>	
7.5S	120	200	<b>2,93</b>	<b>5,51</b>	<b>3,96</b>	<b>4,41</b>	380
$\sigma_{ele}$ Stands for concrete element strength at time of lifting.							
Disclaimer: The table serves solely as a guideline. For accurate guidance and calculations, please contact <a href="http://www.Certex.dk">www.Certex.dk</a> .							

Table 9 Full reinforcement requirements, with u-bar and edge reinforcement.

## 12 Load capacity of Automation spherical anchors in elements – tiles and decking

This section describes the load-bearing capacity of Automation spherical anchors in elements, tiles, and decking elements. Figure 11 shows the placement of the anchors and lifting process, and the anchor's capacity within structures. The table below provides insights that can contribute to an accurate evaluation of the suitability of lifting concrete elements in various scenarios.

Reinforcement requirements see Table 8

- ① Reinforcement mesh
- ④ Diagonal pull bars, only if  $\alpha > 30^\circ$

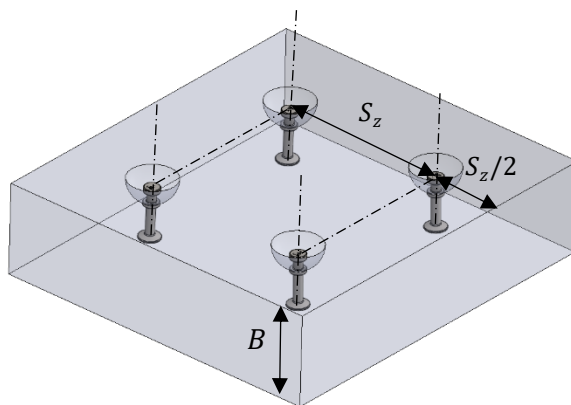

B = Minimal plate thickness

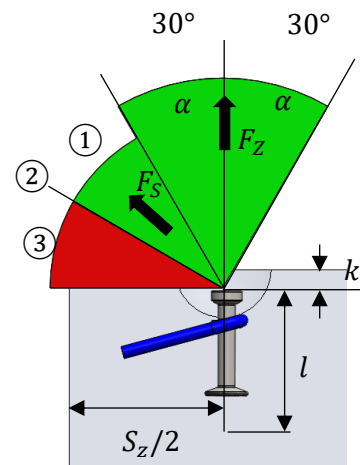

- (1) Diagonal tension at  $30^\circ \leq \alpha \leq 60^\circ$  without reinforcement is only allowed if:
  - Concrete compressive strength ( $\sigma_{ele}$ ) is  $\geq 15$  N/mm<sup>2</sup> and 3 times the minimum wall thickness.
  - Concrete compressive strength ( $\sigma_{ele}$ ) is  $\geq 25$  N/mm<sup>2</sup> and 2.5 times the minimum wall thickness.
  - Concrete compressive strength ( $\sigma_{ele}$ ) is  $\geq 35$  N/mm<sup>2</sup> and 2 times the minimum wall thickness.
- (2) For concrete strength with  $\sigma_{ele} \geq 23$  N/mm<sup>2</sup>, the Safety Factor ( $F_S$ ) equals the Load Factor ( $F_Z$ ).
- (3) Diagonal tension with sling/chain spreading  $\alpha > 60^\circ$  is not permitted.

Figure 11 Reinforcement in elements.



### Lifting a tiles and deck element

Table 10 gives information to assist in determining the appropriate anchors for lifting concrete elements under various loading conditions. The table considers diagonal tension up to 45° ( $\alpha$ ).

The following boundary conditions are utilized for the calculation:

- **1 anchor** symmetrically positioned to the center of gravity.
- **Dynamic factor** (site handling)  $\Gamma_{dyn} = 1.3$
- **Formwork adhesion** is **not** considered.

Load group anchor	Anchor length. L mm	Min. element thickness B mm	Load capacity [Ton] with concrete strength $\sigma_{ele}$				Min. distance between anchors. $S_z$ mm
			Diagonal Pull $\alpha < 45^\circ$ $\gamma < 10^\circ$ 15 N/mm2	Axial Pull $\alpha < 10^\circ$ $\gamma < 10^\circ$ 25 N/mm2	Diagonal Pull $\alpha < 45^\circ$ $\gamma < 10^\circ$ 25 N/mm2	Diagonal Pull $\alpha < 45^\circ$ $\gamma < 10^\circ$ 35 N/mm2	
2.5S	55	120	<b>0,37</b>	<b>0,62</b>	<b>0,45</b>	<b>0,60</b>	380
	68	250	<b>0,39</b>	<b>0,65</b>	<b>0,46</b>	<b>0,79</b>	
	85	180	<b>0,40</b>	<b>0,68</b>	<b>0,49</b>	<b>0,59</b>	
5S	95	200	<b>0,61</b>	<b>1,02</b>	<b>0,73</b>	<b>0,84</b>	380
	120	250	<b>0,63</b>	<b>1,06</b>	<b>0,76</b>	<b>0,87</b>	
7.5S	120	245	<b>0,80</b>	<b>1,35</b>	<b>0,97</b>	<b>1,11</b>	380

$\sigma_{ele}$  Stands for concrete element strength at time of lifting.

Disclaimer: The table serves solely as a guideline. For accurate guidance and calculations, please contact [www.Certex.dk](http://www.Certex.dk).

Table 10 Reinforcement requirements for tiles / decks

## 13 General safety information when using the Starcon system.

General safety information when using the Starcon system.



- Ensure that the marking on the Starcon lifting unit always points in the direction of pull during lifting.
- The lifting machine must be approved to lift at least the maximum applied load + the weight of the Starcon lifting and handling system + any hoisting accessories.
- Lifting movements must be smooth; no sudden or abrupt changes in direction with the lifting machine should be made during a lifting operation, as this can lead to pendulum movements of the load, causing crushing hazards or dropping of the load.
- Where there is a risk of crushing between the load and objects, building parts, machinery, etc., the operator must not be in the danger zone.
- The operator's work area must be flat and free of obstacles that could pose a tripping hazard.
- When depositing the load, the operator must ensure this occurs on a flat and stable surface.
- Only when the load has been deposited and secured the Starcon lifting unit is completely unloaded may it be released and lifted free.
- Before each lift, ensure that both the Starcon lifting unit and the Starcon lifting anchor embedded in the concrete product are free from dirt that could reduce grip.
- Never insert arms or feet under a concrete product.
- Concrete products must never be dragged, only lifted.
- No modifications to the Starcon lifting and handling system may be made without written permission from the manufacturer.
- The operator must always ensure that the connection between the lifting machine and/or any hoisting accessories and the Starcon lifting unit is correct and secured against unintentional detachment.
- The operator must always ensure that the connection between the Starcon lifting unit and the Starcon lifting anchor is correct and secured against unintentional detachment.
- Keep a safe distance and never walk under a suspended load.
- Use gloves, safety shoes and other PPE when handling.
- Never use a Starcon lifting and handling system that has visible defects such as wear, deformations, rust damage, etc.
- Most anchors are designed to be easily handled during installation without the need for lifting equipment. However, some anchors may weigh more and should be handled using lifting equipment. Please refer to the order list for the accurate weight of each product.

## 13.1 Personal Protection

Always use gloves, a safety helmet, and safety shoes as a minimum requirement when operating the equipment. Keep hands and other body parts away from the lifting stand, lifting accessories, and the load during use.



## 13.2 Preparation of the product before use

### 13.2.1 Transport and Storage

Anchors should be transported and stored safely to prevent risks to personnel and nearby objects.

### 13.2.2 Unpacking

Remove the pallet and packaging protecting the anchors.

Cut the safety straps. The person unpacking should wear gloves, safety shoes, and safety glasses when cutting the straps.

### 13.2.3 Safe Disposal of Packaging Materials

All packaging used by Certex Denmark can be reused. Pallets and all wooden packaging can be reused or recycled.

All plastic, cardboard, and paper materials should be sent to the local recycling center.

If there are no local recycling facilities, the packaging should be returned to Certex Denmark for disposal at the customer's expense.

### 13.2.4 Preparatory Work Before Installation

After unpacking, visually inspect the anchors for any damage.

### 13.2.5 Installation and Assembly

The anchors are delivered ready for use.

### 13.2.6 Storage and Protection Between Periods of Normal Use

Inspect the anchors before each use and lift. Never use anchors or lifting accessories with visible defects such as wear, deformations, corrosion damage, etc.

Always store the lifting bar indoors, in a dry and ventilated area.

### 13.2.7 Provision of Information (Users, Operators, Service Experts)

All operators or individuals within the danger zone must receive information on operating the anchors and must be trained by the supervisor, familiarizing themselves with the product and its use before lifting operations commence.

Operators must be trained in the use of the lifting equipment and all its functions and positioned to have a clear view of the entire lifting operation.

### 13.2.8 Placement of Instruction

All user manuals should always be stored together with the lifting equipment.

## 14 Maintenance and inspection

- All maintenance must be performed when the Starcon lifting unit is unloaded.
- The Starcon lifting unit should be inspected and maintained to ensure parts remains in proper condition during use.
- After each use, the Starcon lifting unit should be cleaned and inspected for any faults or deficiencies.
- If any faults are found, they must be rectified, or the Starcon lifting parts should be discarded.
- The Starcon lifting parts should always be stored in a dry and well-ventilated area.
- Any damaged, corroded, or worn-out Starcon lifting parts must be immediately taken out of service and marked not be used again.
- Equipment from Starcon should undergo at least one annual inspection by a qualified skilled person to inspect lifting equipment and cranes.

### 14.1 Maintenance Schedule



- Only original spare parts may be used, and they must be replaced by a trained individual.
- The annual inspection must be carried out by a skilled person who has received the necessary training and certification for lifting equipment.
- All services must be documented, and the data must be stored.
- If there are any visual defects or if the labeling is not present on the lifting stand, the lifting stand must be marked as "out of service".

- B** Before use
- A** After use
- M** Monthly, or a maximum of 200 hours of usage.
- Y** Annually, or after a maximum of 2400 hours of use.

Inspection	B	A	M	Y
Perform a visual inspection to check for signs of overload, deformation, damage, wear, and corrosion.	X	X	X	X
The equipment must undergo inspection.			X	
Ensure that the equipment is ready and clearly labeled.	X			X
Inspection should be carried out by a qualified individual with a report prepared.				X

Table 11 Maintenance schedule

## 15 Disposal / Recycling

This section describes the end of use for the product.

- End of use / Disposal The lifting points shall be sorted / scrapped as general steel scrap.
- The Starcon lifting and handling system should be sorted and disposed of according to appropriate material categories, including metal, plastic, etc.
- Certex can assist you with disposal if required.

## 16 Product data of Automation spherical anchor

Figure 12 shows a measurement sketch for the Automation spherical anchor with labels for the respective dimensions.

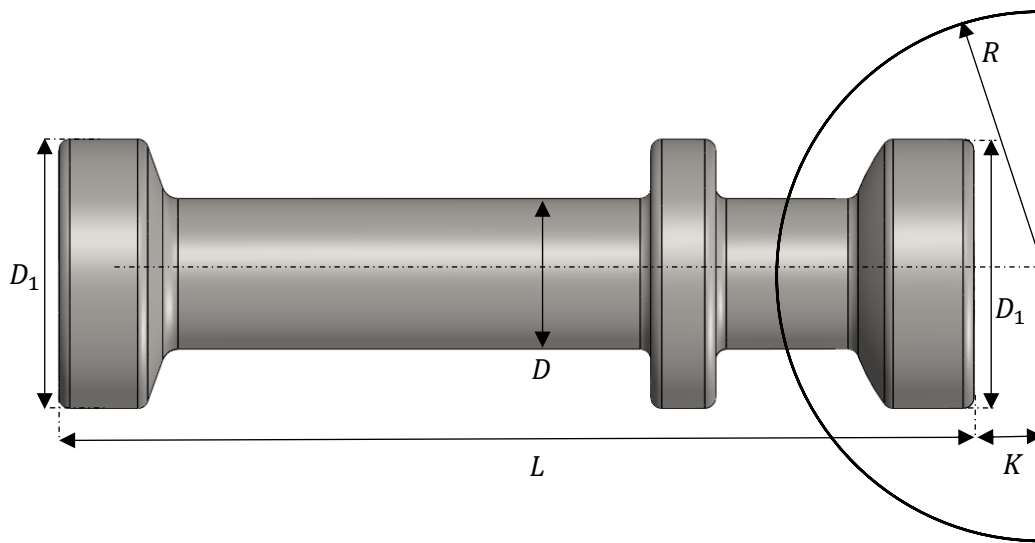

Figure 12 Automation spherical anchor sketch.

### 16.1 Technical data

Table 12 shows the dimensions of the various types of Automation spherical anchors.

Load group	Shaft dia. $D$ <i>mm</i>	Head dia. $D_1$ <i>mm</i>	Foot dia. $D_1$ <i>mm</i>	Cover / Former $K$ <i>mm</i>	Former radius $R$ <i>mm</i>	Anchor length <i>mm</i>
2.5S	14	25	25	11	37	55,68,85
5.0S	20	36	36	15	47	95, 120
7.5S	24	46	46	15	59	120

Table 12 Automation spherical anchor dimension.

## 17 Product data of Starcon lifter universal

Figure 13 shows a measurement sketch for the Starcon lifter universal.

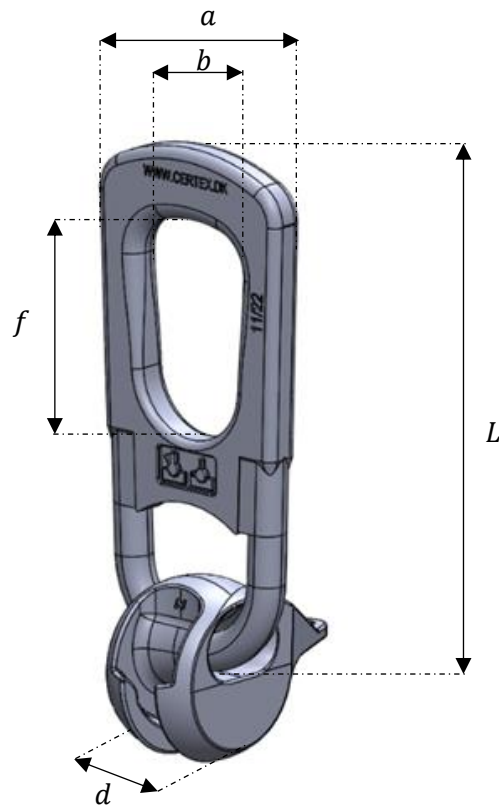

Figure 13 Starcon lifter universal dimension sketch.

### 17.1 Technical data

Table 13 shows the dimensions of the various types of Starcon lifter universal

Load group coupling	Length plate. L mm	Plate width a mm	Hole width b mm	Head width. d mm	Hole height f mm	Thickness of the plate t mm
1. 3S	160	73	43,5	34	70,5	12,5
2. 5S	190	88	50	42	85	14
5. 0S	244	110	67,5	55	88	18
10S	342	159	82	74	116	27
20S	430	183	106	110	123,5	31

Table 13 Starcon lifter universal dimension.

## 18 Product data of Starcon lifting eye flexible coupling

Figure 14 shows a measurement sketch for the Starcon lifting eye flexible coupling.

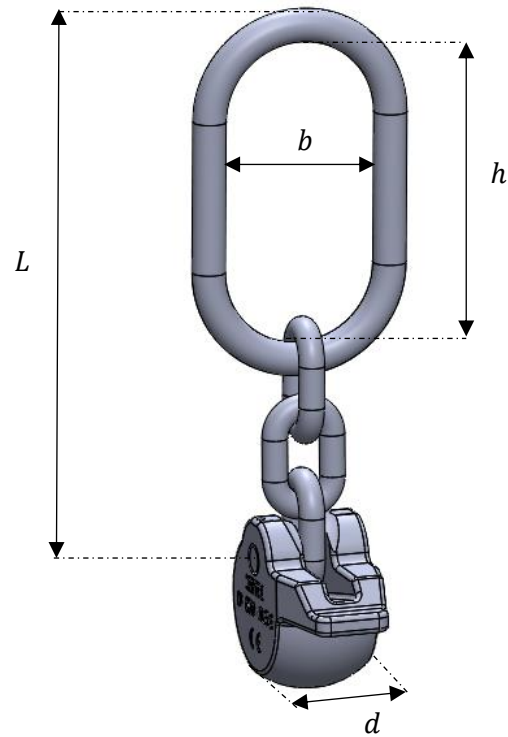

Figure 14 Starcon lifting eye flexible coupling dimension sketch.

### 18.1 Technical data

Table 14 shows the dimensions of the various types of Starcon lifting eye flexible coupling.

Load group coupling	Length plate. $L$ <i>mm</i>	Ring width $b$ <i>mm</i>	Ring height $h$ <i>mm</i>	Head width. $d$ <i>mm</i>
1.3S	182	50	110	34
2.5S	210	60	120	42
5.0S	237	60	120	55
10S	340	100	200	74
20S	484	120	250	110

Table 14 Starcon lifting eye flexible coupling dimension.

## 19 Product data of Starcon lifting eye standard coupling

Figure 15 shows a measurement sketch for the Starcon lifting eye standard coupling.

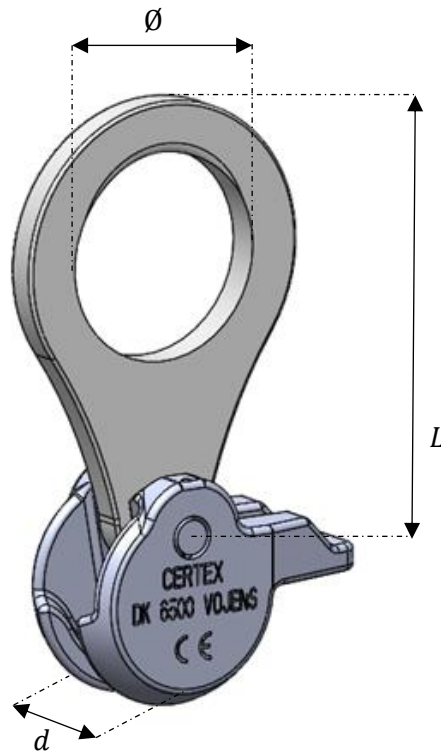

Figure 15 Starcon lifting eye standard coupling dimension sketch.

### 19.1 Technical data

Table 15 shows the dimensions of the various types of Starcon lifting eye standard coupling.

Load group coupling	Length plate. L mm	Plate hole diameter $\varnothing$ mm	Head width. d mm	Thickness of the plate t mm
1.3S	130	42	34	8
2.5S	165	60	42	10
5.0S	200	62	55	12
10S	285	100	74	20
20S	370	120	110	25

Table 15 Starcon lifting eye standard coupling dimension.



## 20 Product data of Starcon former for spherical anchors.

Figure 16 shows a measurement sketch for the Starcon former.

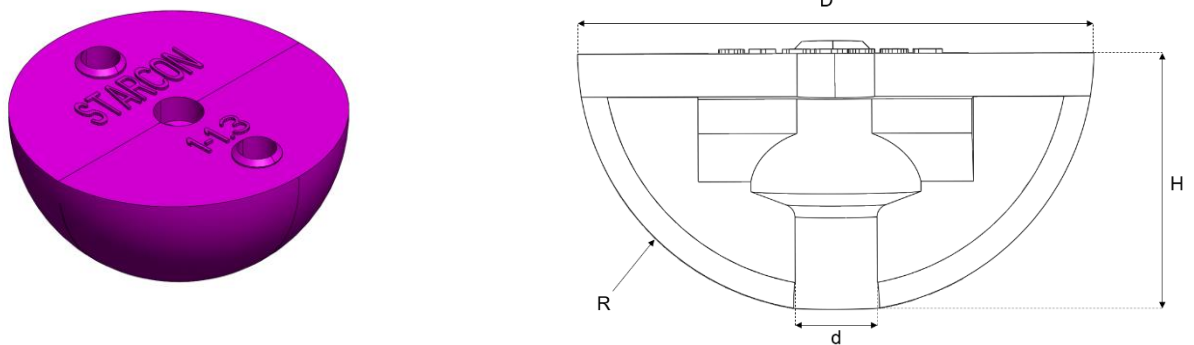

Figure 16 Starcon former for spherical anchors.

### 20.1 Technical data

Table 16 shows the dimensions of the various types of the Starcon former used for casting of the spherical anchors

Former Starcon Load group	D mm	d mm	H mm	R mm	Color
1. 3S	60	10	30	30	Violet
2. 5S	74	14	36	37	Green
5. 0S	94	20	46	47	Red
7. 5S	118	24	58	59	Orange
10S	118	28	58	59	Orange
15S	160	34	78	80	Blue
20S	160	40	98	80	Blue

Table 16 Dimension of Starcon former for spherical anchor.

## 21 EC – Declaration of Conformity of the Machinery

This certificate meets the requirements of the Directive 2006/42/EC Annex II.

Manufacturer and responsible for compiling the technical documentation:

Company:	<b>CERTEX Danmark A/S</b>	Tel. No.:	<b>+45 74 54 14 37</b>
Address:	<b>Trekanten 6-8 6500 Vojens Denmark</b>	E-mail:	<b>info@certex.dk</b>

The undersigned hereby declares that the below specified tool comply with the current safety and health rules and legislation within the European Union. If any changes are made on the tool without approval from the manufacturer, this Declaration no longer applies.

<b>Description:</b>	<b>Automation spherical anchor</b>
<b>Drawing No.:</b>	<b>65011XXXXXXXXXX</b>
<b>Serial No.:</b>	<b>XXXXXX</b>
<b>Lifting Capacity:</b>	<b>WLL pr unit</b>
<b>Own Weight:</b>	<b>Kg pr unit</b>

Is made in accordance with the following EC-directive;  
**2006/42/EC**

The following standards have been used:  
**EN 13155+A2 : 2009**

Date:

---

For CERTEX Danmark A/S

## Our industries, products & services

At CERTEX Denmark, we are a secure and reliable total supplier and partner within lifting equipment. Below is an overview of the industries we service, our product range, and the services we offer."

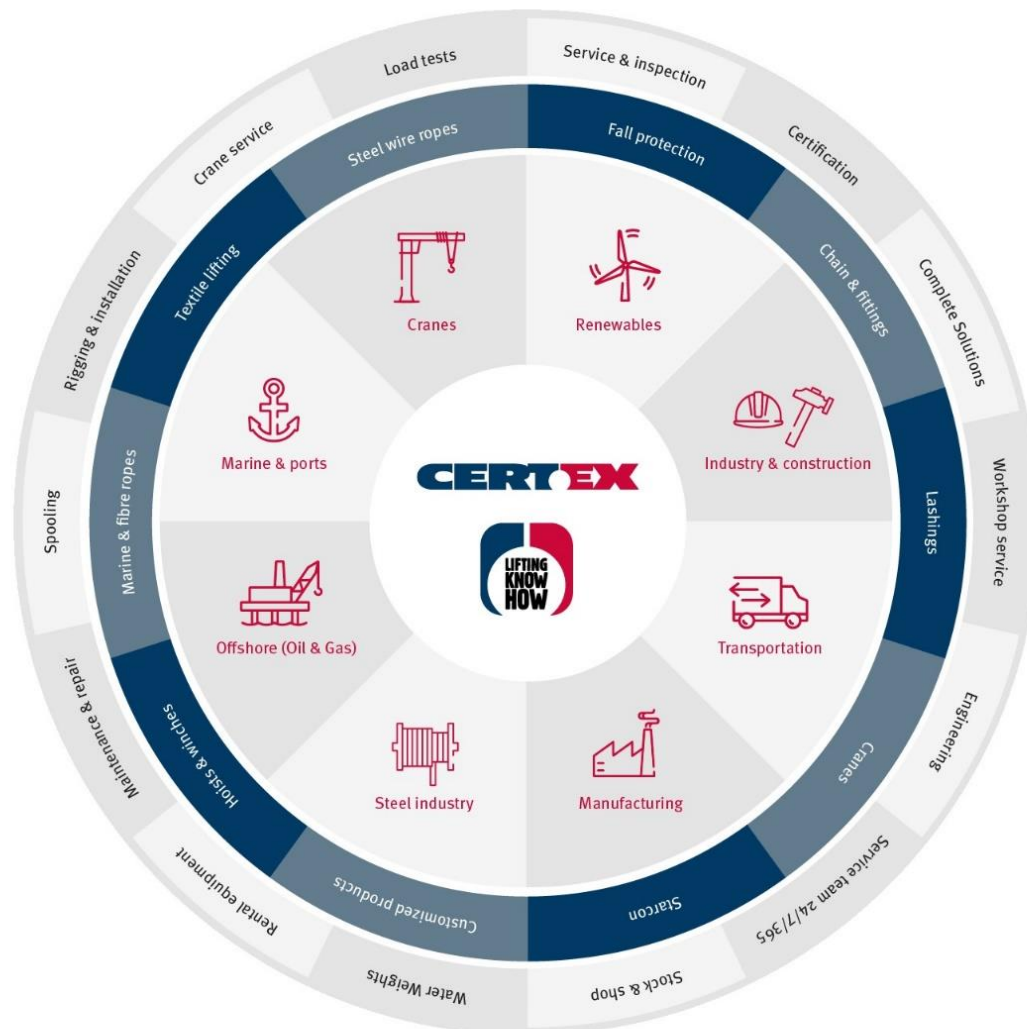

"

**Based on many years of experience  
& know-how within lifting, load  
tests & engineering, CERTEX  
Denmark is your reliable partner &  
supplier of steel wire, lifting  
applications & related services."**