

STARCON



STARCON



Lifting socket solid material system 0.4S to 4S

Lifting and handling systems for concrete elements.

User and design manual

1 Nomenclature

| Symbol | Description | Unit |
|----------------|---|------|
| α | Diagonal pull angle between sling and axial direction | ° |
| β | Tilting angle between element and axial direction | ° |
| γ | Turning angle between element and horizontal direction | ° |
| °C | Temperature Celsius | °C |
| σ_{ele} | Concrete strength of the element at the time of lifting | MPa |
| B | Minimum plate thickness of a tile/slap/deck | mm |
| COG | Center of gravity | [–] |
| D | Anchor shaft diameter | mm |
| D_1 | Nailing plate diameter | mm |
| D_{s1} | Bending diameter of 90° pull bar | mm |
| d_{s1} | Diameter diagonal pull bar | mm |
| D_{s2} | Bending diameter of additional reinforcement | mm |
| d_{s2} | Diameter additional reinforcement | mm |
| d_{bar} | Bending diameter of the diagonal pull bar | mm |
| F_S | Load in diagonal direction | N |
| F_Z | Load in axial direction | N |
| F_L | Load in lateral direction | N |
| K | Nailing plate embedding depth in the concrete element | mm |
| L | Length of the anchor | mm |
| l_{bar} | Total link length of the diagonal pull bar | mm |
| l_s | Length of slot in link | mm |
| l_{s1} | Length of 90° pull bar | mm |
| l_{s2} | Length of additional reinforcement | mm |
| S | Load group symbol (STARCON) | – |
| S_Z | Distance between anchors | mm |
| WLL | Working Load limit | tons |

Table 1 Nomenclature

Starcon Precast Concrete Design & Lifting Manual

| | | |
|----|---|----|
| 1 | Nomenclature | 1 |
| 2 | Identification..... | 2 |
| 3 | Introduction Starcon Lifting socket solid material system 0.4S to 4S | 3 |
| 4 | Safety instructions before use | 4 |
| 5 | Advantages of the Starcon system. | 4 |
| 6 | Using the Starcon system..... | 5 |
| 7 | Safety factors for lifting systems: | 6 |
| 8 | General information | 7 |
| 9 | Design method..... | 9 |
| 10 | Recommend extra support for Lifting socket solid materials in concrete walls..... | 13 |
| 11 | Lifting socket solid material with reinforcement requirements for tilt up and turning. | 15 |
| 12 | Starcon massive transport lifting requirements. | 16 |
| 13 | General safety information when using the Starcon system. | 18 |
| 14 | Maintenance and inspection | 20 |
| 15 | Disposal / Recycling | 21 |
| 16 | Product data of Lifting socket solid materials | 21 |
| 17 | Product data of Lifting loop | 22 |
| 18 | Product data of Alpha inclined pull lifting loop | 23 |
| 19 | Product data of Goliath Lifting loop 40.8..... | 24 |
| 20 | Product data of nailing plates for Lifting socket solid materials..... | 25 |
| 21 | EC – Declaration of Conformity of the Machinery..... | 26 |

2 Identification

Table 2 provides insight into the revision number of this document. It facilitates tracking changes and ensuring version control for accurate referencing and updates.

| Version | Responsible | Creator | Date | Comment |
|---------|----------------|---------|------------|-------------------|
| A | CERTEX Denmark | JLJ | 05-11-2024 | New documentation |
| | | | | |
| | | | | |

Table 2 Revision table

3 Introduction Starcon Lifting socket solid material system 0.4S to 4S

Read this instruction manual before using the Lifting socket solid material. Incorrect use can cause injury or danger!

Safety is paramount when using lifting devices and equipment. Only trained individuals should operate them as per national law. Familiarize yourself with the instruction manual before use to ensure safe operation. Adhering to these guidelines reduces the risk of accidents. Consult relevant national regulations as they may supersede these instructions. All individuals involved with the equipment must read and understand this manual. Contact Certex for assistance or clarification. Always keep the manual with the product. Contact information is provided on the last page.



General concept of the use of Lifting socket solid material:

The Starcon Lifting and Handling System consists of three key components: Starcon Lifting socket solid material, Starcon lifting loop, and Starcon nailing plate shown on Figure 1.

To ensure proper placement of the transport anchor unit in the finished concrete product, the head of the Starcon Lifting socket solid material is assembled into a corresponding Starcon nailing plate before pouring. Once the concrete reaches a strength of at least 15 MPa, the nailing plate can be removed, and transport can commence at the factory. At the installation site, transport can only begin once the concrete has reached a strength of at least 25 MPa. Contact CERTEX DK for lower strength values. Transport can be initiated by attaching the respectably rated lifting loop to the head of the Starcon Lifting socket solid material.

The Starcon Lifting socket solid materials and systems use the guidelines described in the German guidelines VDI/BV-BS 6205 and Technical Report CEN/TR 15728, combined with EN 13155-2009. This ensures the highest level of safety when using our products.

Material: Stainless Steel AISI 316.
Surface treatment: Untreated.



Goliat wirestrop



Lifting socket solid material



Nailing plate

Figure 1 Starcon lifting system.

4 Safety instructions before use



- The Starcon Lifting socket solid material must only be installed on a Starcon nailing plate of the same rating.
- Starcon Lifting socket solid materials that are exposed to corrosion, or damaged must not be used.
- The Starcon Lifting socket solid material must only be hoisted by a lifting loop of the same size.
- The Starcon lifting and handling system must not be used to lift more than the specified load.
- The Starcon lifting and handling system must not be used for personnel lifting.
- The Starcon products are designed for one-time lifting only.
- The Starcon lifting system must only be used by skilled, trained employees.
- A lifting accessory used with the lifting eye must be correctly marked and approved for lifting.
- Before use, check the weather conditions. Never operate the system if there is a likelihood of lightning in the area and avoid use in extreme weather conditions such as storms, heavy rain, or snowing.
- The concrete safety factor assumes a factory production control complying with EN13369. If these requirements are not fulfilled, a safety factor of $\gamma = 2,5$ shall be used.
- All relevant concrete failure modes shall be verified by the pre casting manufacturer of the concrete elements; the different failure modes and verification methods are specified in EN13155 (Annex H).

5 Advantages of the Starcon system.

The Starcon system offers Lifting socket solid materials. These specialized fasteners are used to safely lift and secure precast concrete elements during transportation and installation.

The Starcon system is available in load groups 0.4S to 4S. It is typically embedded in the concrete element during the prefabrication stage and provides a secure lifting point for cranes or hoists. Lifting socket solid materials allow for the attachment of lifting loops or other rigging hardware.

The system's efficiency has been proven through many years of successful use and numerous laboratory tests. Components are regularly tested during production and are clearly marked with the maximum load. The Lifting socket solid materials are individually tested and come with a traceability batch code.

5.1 Note

The information in this manual is for guidance only, and the use of the manual does not in any way exempt the manufacturer from ensuring that the chosen lifting system is suitable for the intended purpose. The information and data listed in this manual only refer to original Starcon products supplied by *CERTEX DANMARK A/S*.

6 Using the Starcon system

The Starcon system comprises a wide range of anchors in a load group from 0.4S to 4S per anchor with various lengths. The principle for using the system is the same for the entire range. The Starcon system consists of the following three main components:

6.1 Starcon Lifting socket solid material

The Starcon Lifting socket solid material is a steel embedded member with a specially designed foot for secure anchoring in hardened concrete. The Starcon Lifting socket solid material head, a cylindrical, internally threaded unit, connects to the Starcon lifting loop. Starcon Lifting socket solid materials are clearly labelled with dimensions (e.g. 0.4S) and are available in a variety of lengths. They undergo specimen testing for defects, dimensional deviation and tensile strength with a minimum safety factor of 3:1 against metal failure.

6.2 Starcon Nailing plate

The nailing plate, typically made of round plastic components with a threaded end, must be carefully attached to the anchor head and positioned correctly before being securely fastened to the formwork. After the concrete cures and hardens, the nailing plate is removed, exposing the anchor head seated in a cylindrical depression. Since the nailing plate is typically stripped and unscrewed during removal, it's not normally reusable.

Magnetic nailing plates, made of steel and plastic components, can be disassembled, unscrewed, cleaned, and stored for reuse after removal.

6.3 Starcon Lifting Loop

Starcon lifting loops are devices used to attach cables or slings to objects for lifting. Typically made of forged steel, they come in various shapes and sizes to suit different lifting capacities and applications. Starcon lifting loops undergo rigorous testing to ensure their safety. They are tested to twice their allowable load, and all test results are meticulously recorded. Each loop is marked with its article number, identification number, and maximum working load, along with a clear indication of a 4:1 safety factor. Additionally, a certificate is issued with every delivery for complete documentation.

An additional safety measure is that the Starcon system is available in several non-compatible load groups. It is not possible to incorrectly assemble components from different load groups, thus avoiding failure of the lifting arrangement.

6.4 Lifting loop assembly instructions.

Screw the lifting loop by hand into the threaded hole of the Lifting socket solid material. Ensure the threads engage fully and easily without any cross-threading. If necessary for proper sling alignment during lifting, you may loosen the connection by one turn of the lifting loop. The system allows safe lifting in a vertical direction and up to a maximum tilt angle of 30 degrees in all directions. It is not to be used for turning or pitching a load. The instruction is shown and explained in Table 3.

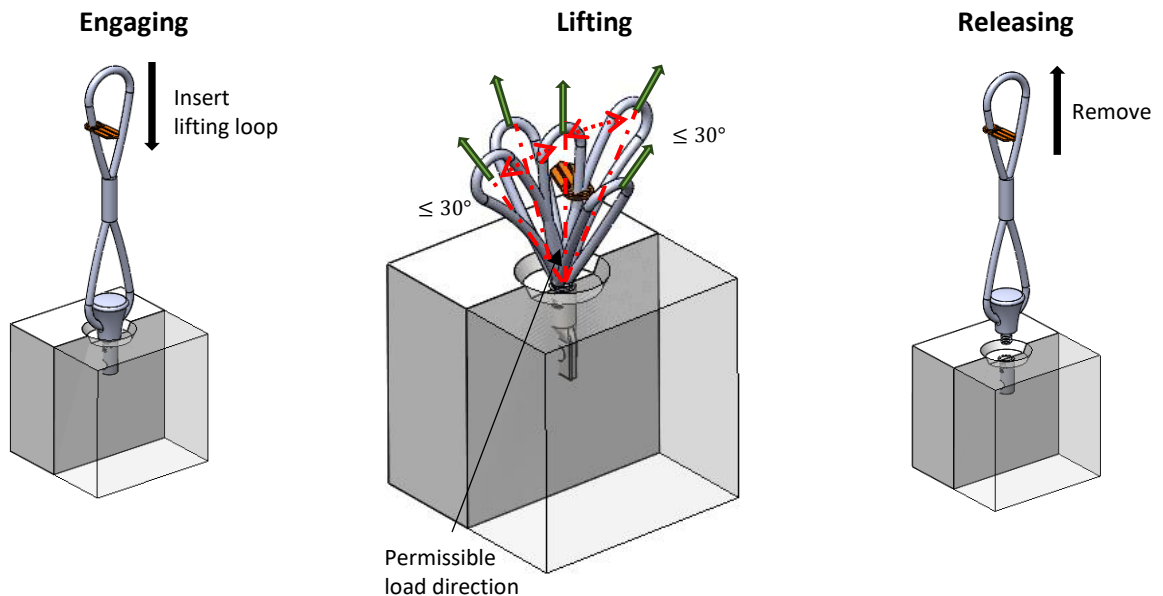

Verify that the Lifting socket solid material load capacity matches the Lifting loop.

Manually insert the Lifting loop into the Lifting socket solid material.

Once hand-tight, visually check that the Lifting loop sits flush against the Lifting socket solid material. You can begin the lifting process.

Table 3 The connection between the lifting loop and transport anchor.

Lifting loops are designed to handle loads in vertical and tilted orientations, provided the load limits of the transport anchors are not exceeded. The tilt lift should normally not exceed 30 degrees in all directions. When using a spreader beam, the tilt angle of the load can be reduced.

Manually disconnect the Lifting loop by turning it out of the Lifting socket solid material.

7 Safety factors for lifting systems:

For the calculations of the lifting system, the following safety factors shown Table 4 have been applied to ensure its reliability and safety. These factors, in accordance with the recommendation of EN13155, have been carefully selected as guidelines to ensure optimal safety during the system's operation.

| Failure safety factors | |
|-----------------------------|-----------------------|
| Steel failure of anchors | $SF_{Steel} = 3$ |
| Concrete pull out failure | $SF_{concrete} = 2,5$ |
| Failure in the lifting loop | $SF_{Link} = 4$ |

Table 4 Failure safety factors

8 General information

This section provides essential details on the Starcon Lifting socket solid material systems, offering clarity and guidance for safe and efficient usage.

8.1 Marking on the transport anchor

Each Lifting socket solid material is clearly labeled with its load capacity, length, and manufacturer's identification, ensuring easy and secure identification of the systems, even post-installation show on Figure 2.

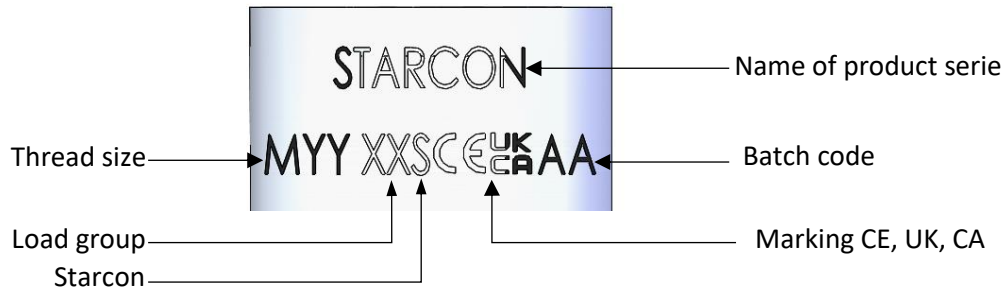

Figure 2 Marking on the cylinder of the transport anchor.

8.2 Guidelines for Lifting socket solid material selection

When selecting Lifting socket solid materials, it's essential to consider various factors to ensure safety and effectiveness. The tables provided contain crucial information such as maximum load capacities, edge distances, and installation values for different transport anchor types. Key points to consider:

- Weight of the precast element.
- The number of Lifting socket solid materials.
- How the anchors are arranged.
- The load-bearing capacity of the Lifting socket solid materials
- Sling handling angle.
- The diagonal pulls properties of the Lifting socket solid materials.
- Environmental impact on the use.

8.3 Guidelines for installation

For the Starcon massive transport lifting anchor systems to be appropriately installed, it is imperative to ensure compliance with specific technical criteria and prerequisites:

- Adherence to load capacity specifications of the anchor.
- Maintaining appropriate edge spacing.
- Ensuring the concrete grade is suitable.
- Verifying alignment with the load direction.
- Additional reinforcement requirements.

8.4 Guideline for load capacity

Load capacity of an anchor relies on several factors:

- The strength of the concrete at the moment of lifting, as determined by a cube-test with dimensions of 15 × 15 × 15 cm.
- The length of the anchor.
- The spacing between the anchor and the edges, both axially and along the edge.

Lifting and handling systems for concrete elements.

- The direction of the applied load.
- The arrangement of reinforcement within the concrete structure.

9 Design method

This section covers the design method for lifting operations as well as illustrations of various lifting techniques. It describes when the different types of lifts occur, including axial lifting, diagonal lifting, tilting, and rotation of elements. Additionally, the casting process is discussed, including the transfer of load to the concrete using the anchor base, and the importance of correctly placing formwork and anchors during casting to avoid errors and risks. Warnings are given regarding the correct size of formwork and the risk of errors with incorrect sizes, which can lead to potentially dangerous situations.

9.1 Illustration of lifting methods

Figure 3 shows a description of when the different types of lifts occur:

- **Axial pull:** occurs in the same direction as the pulling force and happens within the range of $0^\circ \leq \alpha \leq 10^\circ$.
- **Diagonal pull:** occurs when slings/chains are angled between $10^\circ \leq \alpha \leq 45^\circ$ relative to the lift.
- **Tilting:** occurs when the object needs to rotate around its COG on the long side of the element.
- **Turning:** occurs when the object needs to rotate around its COG on the long side of the element

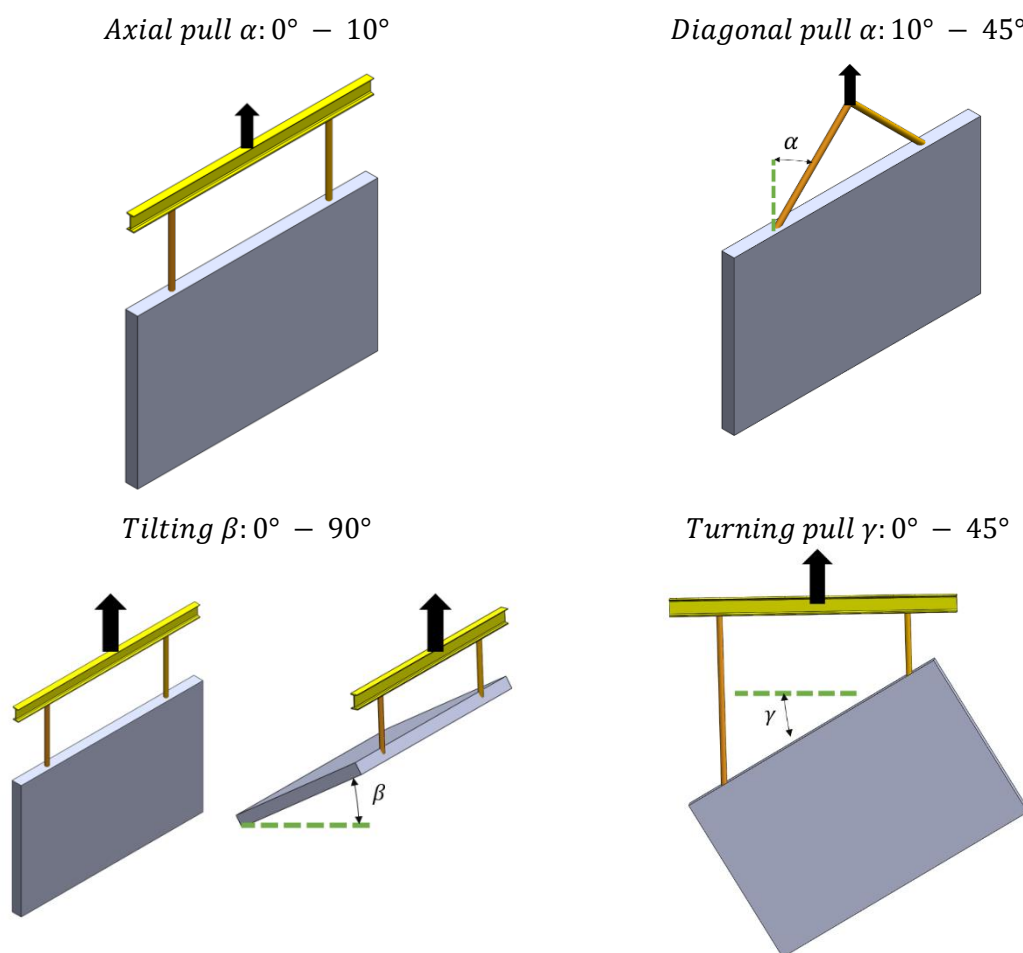

Figure 3 Lifting methods.

9.2 Correct placement of nailing and Lifting socket solid materials during cast

Caution: If the nailing plate is too small, it won't be compatible with the lifting equipment later. Conversely, if the recess block is too large, attaching the lifting equipment correctly will be impossible, increasing the risk of the Lifting loop slipping out. This could lead to premature Lifting socket solid material failure and the subsequent collapse of the construction element. Always ensure the nailing size matches the identified appropriate size. Figure 4 illustrates the correct placement of the nailing plate in wet concrete to ensure optimal anchorage strength for the Lifting socket solid material.

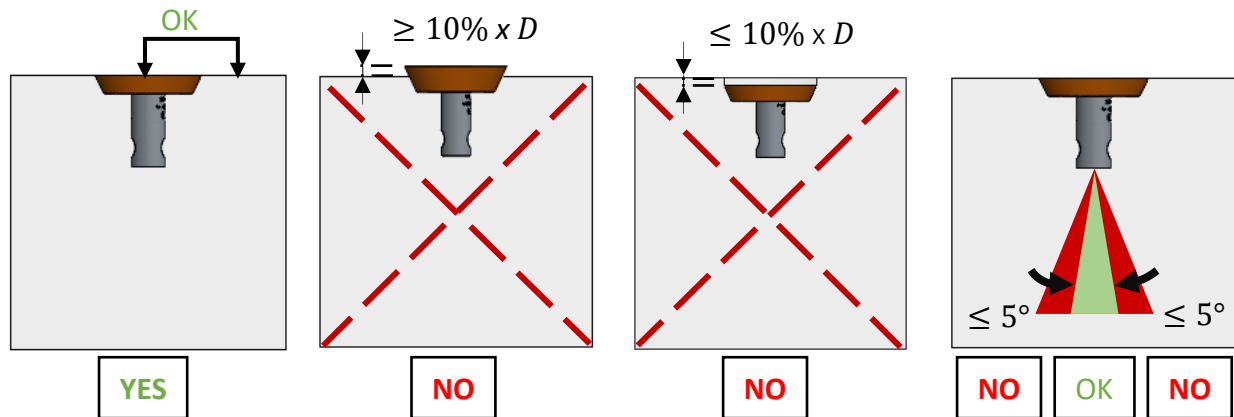

Figure 4 Correct placement of nailing plate.

9.3 Calculate load cases of removing from formwork and transport.

To ensure proper anchoring, each anchor must consider several factors: weight of the element, adhesion to the mold, shock load, sling angle, and the number and position of the anchors.

When lifting a concrete unit from a form, consider the adhesion factor between the concrete and the mold. For complex shapes, adhesion can increase anchor load, especially when concrete strength is at its lowest. Calculate the total weight of the elements in tons, including all equipment and accessories attached to the device.

9.3.1 Load case removing the formwork and transport of the element.

The tension force F_A in each the anchor:

1. Load case when removing the element from the formwork:
$$F_A = \frac{(F_Z + S * P a) * F_S}{n}$$

2. Load Case during transport lifting of the element.
$$F_A = \frac{F_Z * F_S * \varphi_{dyn}}{n}$$

Where,

- F_Z : Weight of the concrete element in Tons (*tonne*)
- S : Surface area of the mould in contact with the fresh concrete (m^2)
- Pa : Adhesion factor between the pouring box and concrete (See Table 6)
- F_S : Sling angle factor (See Table 5)
- n : Number of load-bearing anchors in the element.
- φ_{dyn} : Dynamic factor of the element under transport

9.3.2 Sling angle factor (F_S)

The illustration in Figure 5 provides a visual explanation of how to measure the sling angle. Referencing Table 5, you can find the sling factor corresponding to the measured angle.

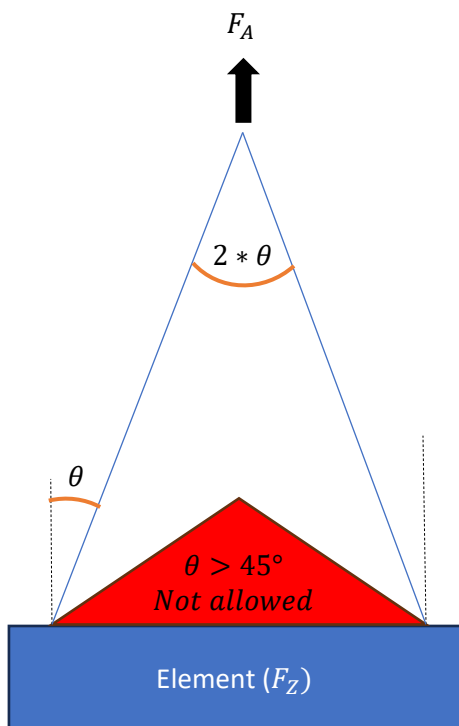

Figure 5 Sling angle factor illustration.

| Sling angle degree (θ) | Sling factor (F_S) |
|---------------------------------|------------------------|
| 0° | 1 |
| 10° | 1,02 |
| 20° | 1,07 |
| 30° | 1,16 |
| 45° | 1,41 |

Table 5 Sling angle factor

9.3.3 Adhesion to formwork factors (Pa)

Adhesion factor between the pouring box and concrete is shown in Table 6.

| Mould type | Adhesion ($\frac{\text{tonnes}}{\text{m}^2}$) |
|----------------------------|---|
| Lubricated steel form work | $Pa = 0,1$ |
| Varnished timber formwork | $Pa = 0,2$ |
| Rough formwork | $Pa = 0,3$ |

Table 6 Adhesion factor to formwork

9.3.4 Dynamic factors (φ_{dyn})

If the concrete unit is handled or transported by mechanical equipment, it is exposed to shock/impact from gripping and transport over uneven ground. This factor can increase the anchor load several times its own weight. The correct load can be determined by adding the dynamic factor φ_{dyn} shown in Table 7

| Lifting condition | Dynamic load factor |
|---|---------------------|
| Static crane, rope speed <90 m/min | 1 |
| Static crane, rope speed >90 m/min | 1,3 |
| Lift and transport with mobile crane on smooth ground | 1,75 |
| Lift and transport with mobile crane on uneven ground | 2 |
| Transport with forklift or excavator over uneven ground | 3 |

Table 7 Dynamic factor

9.3.5 The number and position of lifting points

The effective load carried by each anchor is typically calculated by dividing the total weight by the number of load-bearing anchors. However, this calculation assumes equal load distribution among all anchors. If the load distribution is unequal, the load to be carried by each anchor should be determined using static calculations as shown in Figure 6.

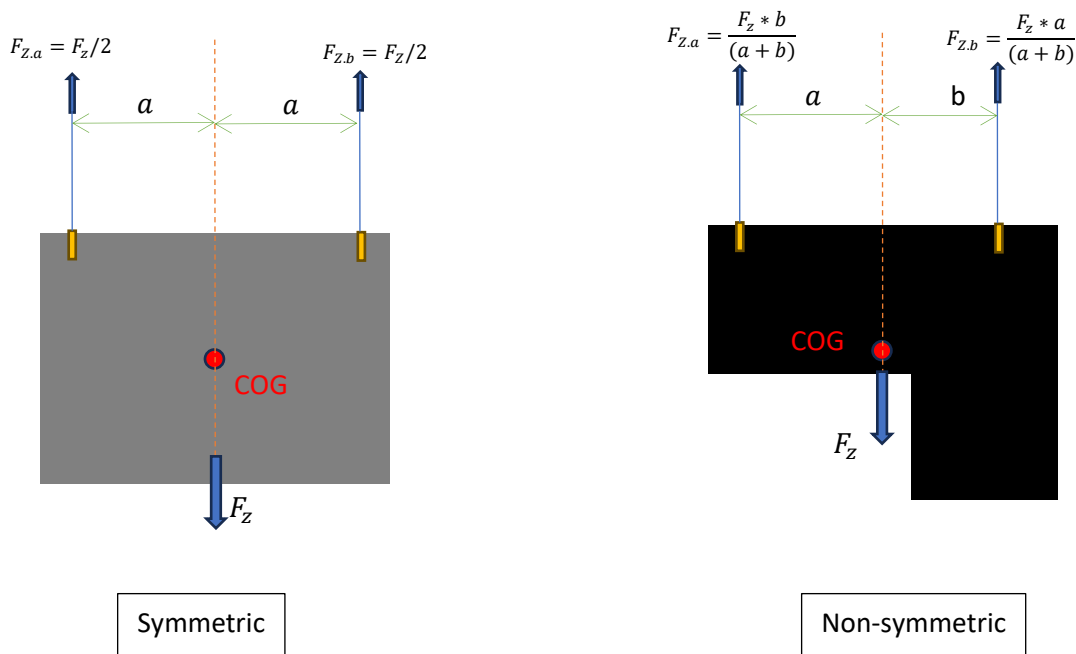

Figure 6 Calculation symmetric and non-symmetric loading element.

10 Recommend extra support for Lifting socket solid materials in concrete walls

Figure 7 shows how to correctly position the reinforcement mesh inside the element. It also demonstrates the correct placement of diagonal pull bars to effectively support the anchor and the opposite face during lifting operations. The anchorage reinforcement, classified as B500B according to DIN 488 standards as shown in the illustration.

- The diagonal pull reinforcement should be positioned as near as possible beneath the former and must be installed in full contact with the anchor.

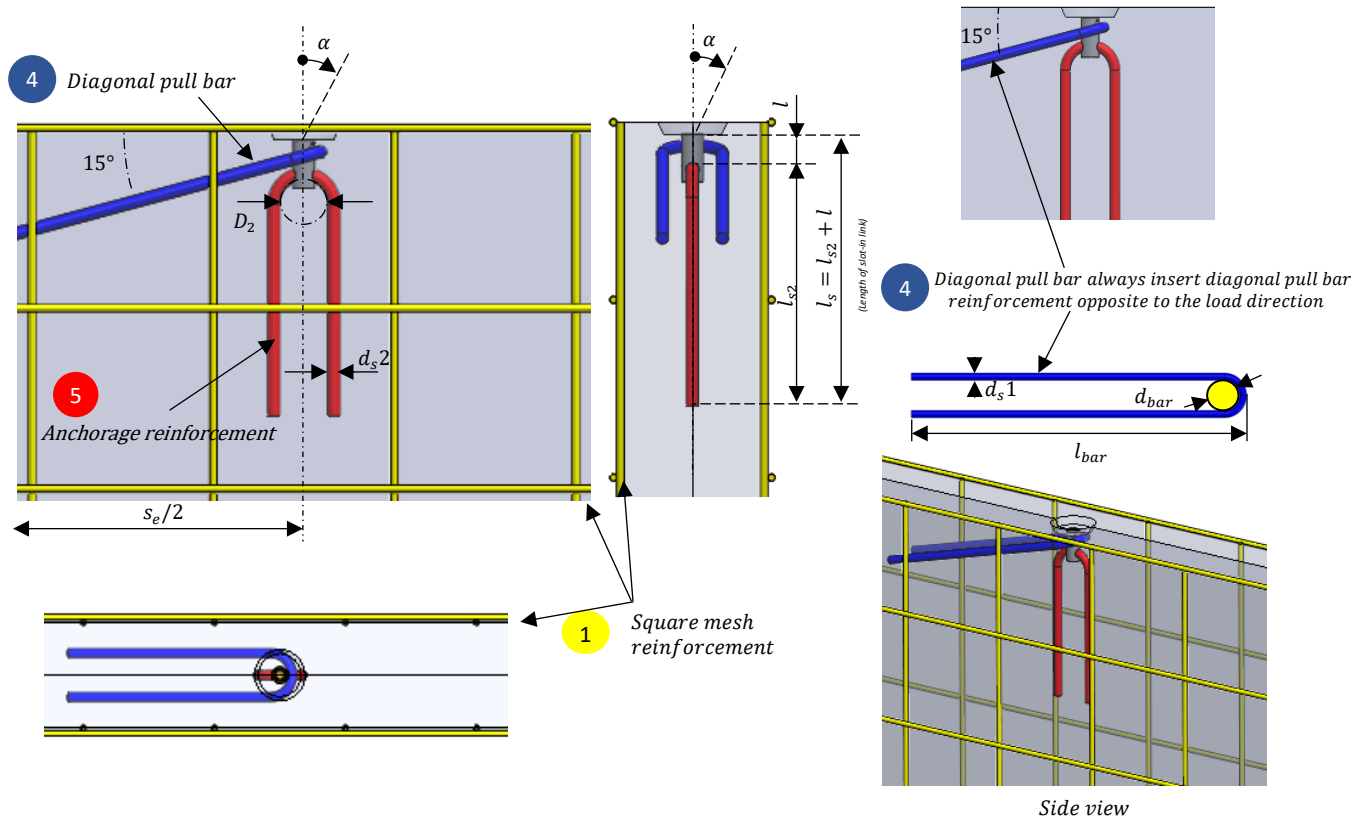

Figure 7 Reinforcement in the concrete wall

Table 8 provides a detailed description of the correct placement of mesh and reinforcement within the concrete for each anchor type.

| Load group | Dimension of Lifting socket solid material | ① | ④ | | | ⑤ | | |
|------------|--|--|--------------------------|-----------------|-----------------|------------------------------|-------------|----------------|
| | | Square mesh reinforcement ① mm^2/m | Diagonal pull bar ⑤ ⑥ | | | Anchorage reinforcement ② | | |
| | | | $d_s 1$ mm | d_{bar} mm | l_{bar} mm | $d_s 2$ mm | D_2 mm | l_{s2} mm |
| 0.4S | M10 x 42 | 2 x 131 | Ø6 | 24 | 130 | Ø8 | 60 | 250 |
| 0.5S | M12 x 40 | 2 x 131 | Ø8 | 32 | 130 | Ø8 | 60 | 300 |
| | M12 x 49 | 2 x 131 | Ø8 | 32 | 130 | Ø8 | 70 | 350 |
| 1.2S | M16 x 50 | 2 x 131 | Ø8 | 32 | 170 | Ø10 | 70 | 350 |
| | M16 x 56 | 2 x 131 | Ø8 | 32 | 170 | Ø10 | 70 | 350 |
| 2S | M20 x 68 | 2 x 131 | Ø10 | 40 | 220 | Ø12 | 80 | 400 |
| | M20 x 78 | 2 x 131 | Ø10 | 40 | 220 | Ø12 | 80 | 400 |
| | M20 x 87 | 2 x 131 | Ø10 | 40 | 220 | Ø12 | 80 | 400 |
| 2.5S | M24 x 80 | 2 x 131 | Ø10 | 40 | 240 | Ø12 | 100 | 450 |
| 4S | M30 x 103 | 2 x 131 | Ø14 | 56 | 265 | Ø16 | 135 | 600 |

① To ensure optimal spacing, the utilization of concise anchors alongside a substantial minimum quantity of u-bars is mandated, with a requirement for intervals not exceeding 150 mm.

② To determine the length of the link (l_s), add the length of the anchor (l) to the corresponding value (l_1) obtained from the provided table.

⑤ To ascertain the necessity of diagonal load up reinforcement, refer to the load tables, particularly when $\alpha < 45^\circ$.

⑥ To ensure proper reinforcement alignment, in cases where the precast element's dimensions limit the diagonal pull reinforcement length, it's permissible to bend the last 40% of the bar into a loop shape.

Disclaimer: The table serves solely as a guide. For accurate guidance and calculations, please contact www.Certex.dk.

Table 8 Reinforcement data for elements

11 Lifting socket solid material with reinforcement requirements for tilt up and turning.

This description aims to provide an understanding of the load capacity of the anchors when the element is lifted with either tilting or turning, as well as the dimensions and location of the reinforcement as shown on Figure 9. The table below provides insights that can contribute to an accurate evaluation of the suitability of lifting concrete elements in various scenarios.

The anchor needs to be positioned correctly, as illustrated.

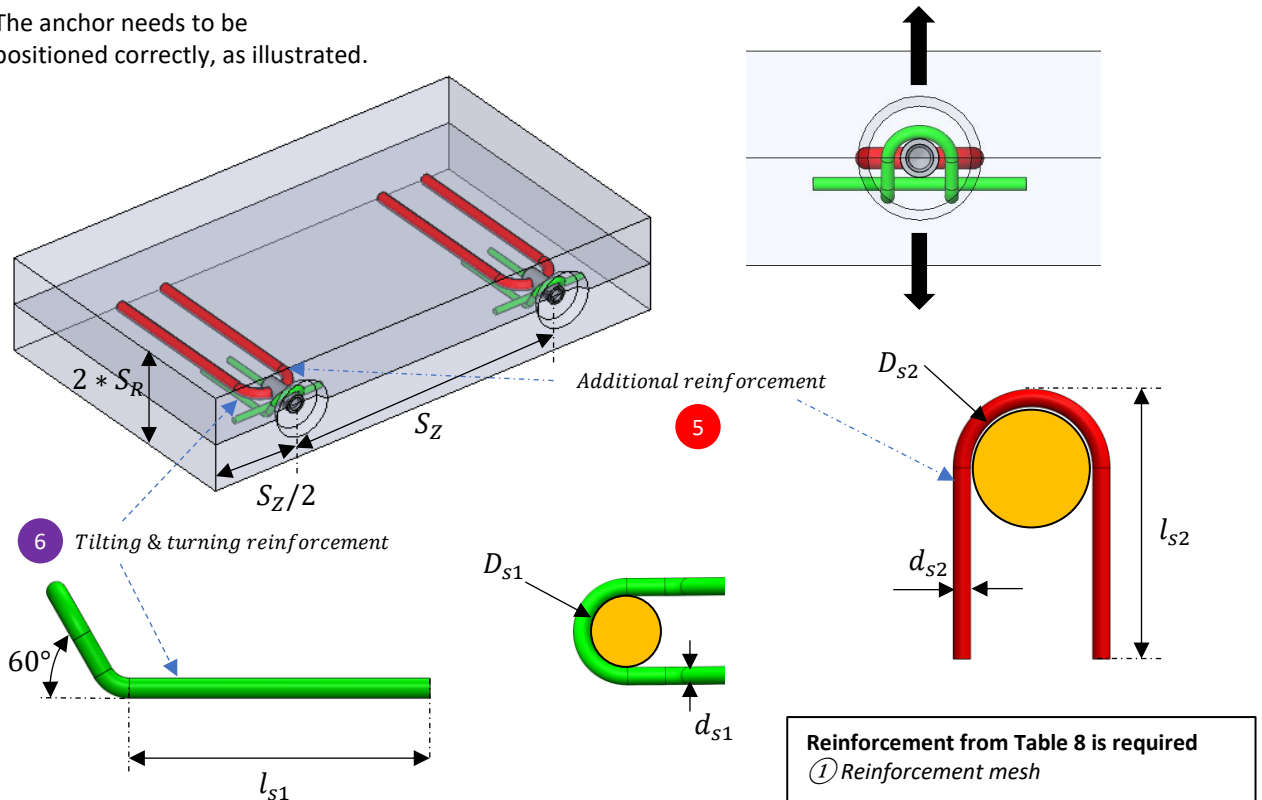

Figure 8 Reinforcement requirements for tilting and turning of the element.

Reinforcement in the anchor zone for a wall

Table 9 provides information to assist in determining the appropriate anchors for lifting concrete elements under various loading conditions.

| Load group | Dimension of Lifting socket solid material | ⑥ Tilting and turning reinforcement requirements at $\sigma_{ele} \geq 15 \text{ N/mm}^2$ and $\sigma_{ele} \geq 25 \text{ N/mm}^2$ | | | ⑤ Additional Pull reinforcement requirements at $\sigma_{ele} \geq 15 \text{ N/mm}^2$ and $\sigma_{ele} \geq 25 \text{ N/mm}^2$ | | |
|------------|--|---|----------------|----------------|---|----------------|----------------|
| | | d_{s1} ① mm | D_{s1} mm | l_{s1} mm | d_{s2} mm | D_{s2} mm | l_{s2} mm |
| 0.4S | M10 x 42 | Ø8 | 32 | 95 | Ø8 | 60 | 250 |
| 0.5S | M12 x 40 | Ø8 | 32 | 95 | Ø8 | 60 | 300 |
| | M12 x 49 | Ø8 | 32 | 95 | Ø8 | 70 | 350 |
| 1.2S | M16 x 50 | Ø8 | 32 | 130 | Ø10 | 70 | 350 |
| | M16 x 56 | Ø8 | 32 | 130 | Ø10 | 70 | 350 |
| 2S | M20 x 68 | Ø10 | 40 | 185 | Ø12 | 80 | 400 |
| | M20 x 78 | Ø10 | 40 | 185 | Ø12 | 80 | 400 |
| | M20 x 87 | Ø10 | 40 | 185 | Ø12 | 80 | 400 |
| 2.5S | M24 x 80 | Ø10 | 40 | 185 | Ø14 | 100 | 450 |
| 4S | M30 x 103 | Ø14 | 64 | 195 | Ø16 | 135 | 600 |

σ_{ele} Stands for concrete element strength at time of lifting.

Disclaimer: The table serves solely as a guideline. For accurate guidance and calculations, please contact www.Certex.dk.

① Reinforcement from requirements from Table 8, with reinforcement mesh is required.

Table 9 Reinforcement requirements, in anchor zone for tilting, turning and pull.

12 Starcon massive transport lifting requirements.

This description aims to provide an understanding of the capacity of these anchors within structures with special reinforcements shown on Figure 9, including the following components, Reinforcement mesh, diagonal pull bars only if, $\alpha \geq 10^\circ \leq 45^\circ$, and pull reinforcement. The table below provides insights that can contribute to an accurate evaluation of the suitability of lifting concrete elements in various scenarios.

- The angle at the lifting point must not exceed $\alpha > 45^\circ$. This is not allowed!

Reinforcement requirements see Table 8

- ① Reinforcement mesh
- ④ Diagonal pull bars, if $\alpha \geq 10^\circ \leq 45^\circ$
- ⑤ Additional reinforcement

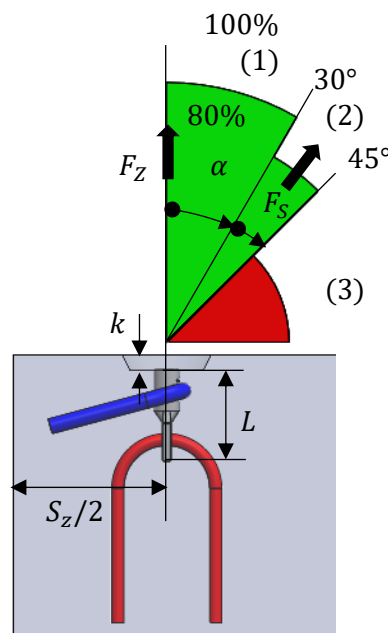
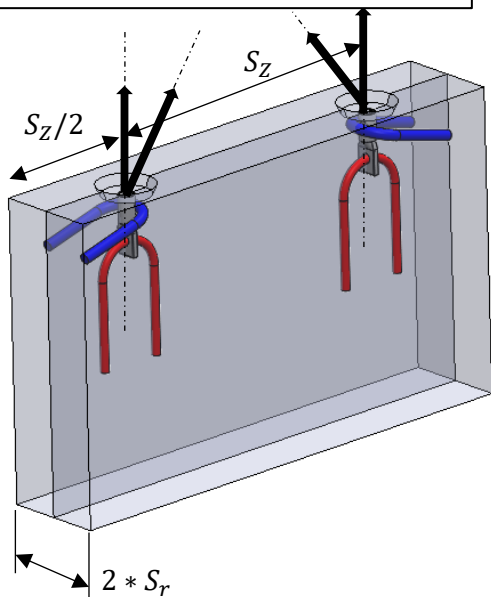

Axial & Diagonal pull lifting

Reinforcement requirements see Table 9

- ① Reinforcement mesh
- ④ Diagonal pull bars, if $\beta \geq 0^\circ - 60^\circ$ (β must not exceed 60°)
- ⑤ Pull reinforcement

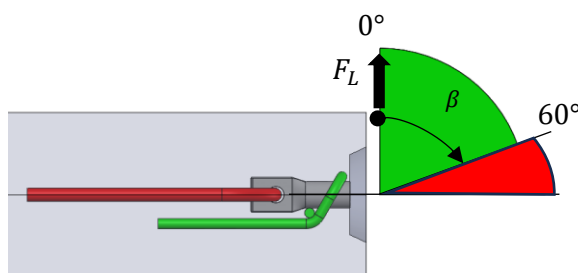
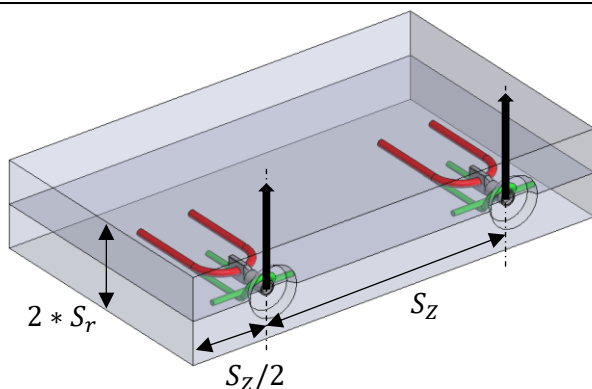

Tilt-up and turning lifting

(1) Diagonal tension at $0^\circ \leq \alpha \leq 45^\circ$ without reinforcement is only allowed if:

- Concrete compressive strength (σ_{ele}) is $\geq 15 \text{ N/mm}^2$ and 3 times the minimum wall thickness,
- Concrete compressive strength (σ_{ele}) is $\geq 25 \text{ N/mm}^2$ and 2.5 times the minimum wall thickness,

(2) For concrete strength with $\sigma_{ele} \geq 23 \text{ N/mm}^2$, the Safety Factor (F_S) equals the Load Factor (F_Z).

(3) Diagonal tension with cable/chain spreading $\alpha > 45^\circ$ is not permitted.

Figure 9 Reinforcement requirements.

Lifting a Wall Element

Table 10 provides information to assist in determining the appropriate anchors for lifting concrete elements under various loading conditions. The table considers both diagonal tensions up to $45^\circ (\alpha)$ and transverse tension up to $10^\circ (\gamma)$.

The following boundary conditions are utilized for the calculation:

- **1 anchor** symmetrically positioned to the center of gravity.
- **Dynamic factor** (site handling) $\Gamma_{dyn} = 1.3$
- **Formwork adhesion** is not considered.

| Load group | Anchor length. L mm | Min. wall thickness $2 * S_r$ mm | Load capacity [Ton] with concrete strength σ_{ele} | | | | | | | | | | Min. distance between anchors. S_z mm |
|------------|-----------------------------------|--|---|-------------------------------|--|--------------|---------|--|--------------|---------|---|---|---|
| | | | Axial Load $15 N/mm^2$ | Axial Load $25 N/mm^2$ | Diagonal Load $\alpha \leq 45^\circ$ $15 N/mm^2$ | | | Diagonal Load $\alpha \leq 45^\circ$ $25 N/mm^2$ | | | Lateral Load $\gamma \leq 90^\circ$ $15 N/mm^2$ | Lateral Load $\gamma \leq 90^\circ$ $25 N/mm^2$ | |
| | | | All lifting loops | All lifting loops | Alpha loop | Goliath loop | List 42 | Alpha loop | Goliath loop | List 42 | Alpha / Goliath | Alpha / Goliath | |
| 0.4S | 42 | 80 | 0,63 | 0,71 | 0,63 | 0,55 | 0,31 | 0,63 | 0,55 | 0,31 | 0,29 | 0,38 | 280 |
| 0.5S | 40 | 80 | 0,86 | 0,94 | 1,02 | 0,63 | 0,47 | 1,26 | 1,02 | 0,47 | 0,32 | 0,42 | 280 |
| | 49 | 80 | 0,86 | 0,94 | 1,02 | 0,63 | 0,47 | 1,26 | 1,02 | 0,47 | 0,32 | 0,42 | |
| 1.2S | 50 | 100 | 1,33 | 1,41 | 1,26 | 1,02 | 1,02 | 1,65 | 1,26 | 1,02 | 0,49 | 0,63 | 360 |
| | 56 | 100 | 1,33 | 1,41 | 1,26 | 1,02 | 1,02 | 1,65 | 1,26 | 1,02 | 0,49 | 0,63 | |
| 2S | 68 | 120 | 2,35 | 2,83 | 2,35 | 1,65 | 1,57 | 2,75 | 2,12 | 1,57 | 0,94 | 1,22 | 500 |
| | 78 | 120 | 2,35 | 2,83 | 2,35 | 1,65 | 1,57 | 2,75 | 2,12 | 1,57 | 0,94 | 1,22 | |
| | 87 | 120 | 2,35 | 2,83 | 2,35 | 1,65 | 1,57 | 2,75 | 2,12 | 1,57 | 0,94 | 1,22 | |
| 2.5S | 80 | 120 | 2,90 | 3,14 | 2,43 | 1,96 | 1,96 | 3,22 | 2,43 | 1,96 | 1 | 1,3 | 600 |
| 4S | 103 | 160 | 3,77 | 3,14 | 3,45 | 3,14 | 3,14 | 4,31 | 3,22 | 3,14 | 1,63 | 2,1 | 700 |

σ_{ele} Stands for concrete element strength at time of lifting.

Disclaimer: The table serves solely as a guideline. For accurate guidance and calculations, please contact www.Certex.dk.

Table 10 Standard reinforcement requirements.

13 General safety information when using the Starcon system.

General safety information when using the Starcon system.



- Ensure that the marking on the Starcon lifting unit always points in the direction of pull during lifting.
- The lifting machine must be approved to lift at least the maximum applied load + the weight of the Starcon lifting and handling system + any hoisting accessories.
- Lifting movements must be smooth; no sudden or abrupt changes in direction with the lifting machine should be made during a lifting operation, as this can lead to pendulum movements of the load, causing crushing hazards or dropping of the load.
- Where there is a risk of crushing between the load and objects, building parts, machinery, etc., the operator must not be in the danger zone.
- The operator's work area must be flat and free of obstacles that could pose a tripping hazard.
- When depositing the load, the operator must ensure this accepts on a flat and stable surface.
- Only when the load has been deposited and secured the Starcon lifting unit is completely unloaded may it be released and lifted free.
- Before each lift, ensure that both the Starcon lifting unit and the Starcon lifting anchor embedded in the concrete product are free from dirt that could reduce grip.
- Never insert arms or feet under a concrete product.
- Concrete products must never be dragged, only lifted.
- No modifications to the Starcon lifting and handling system may be made without written permission from the manufacturer.
- The operator must always ensure that the connection between the lifting machine and/or any hoisting accessories and the Starcon lifting unit is correct and secured against unintentional detachment.
- The operator must always ensure that the connection between the Starcon lifting unit and the Starcon lifting anchor is correct and secured against unintentional detachment.
- Keep a safe distance and never walk under a suspended load.
- Use gloves, safety shoes and other PPE when handling.
- Never use a Starcon lifting and handling system that has visible defects such as wear, deformations, rust damage, etc.
- Most anchors are designed to be easily handled during installation without the need for lifting equipment. However, some anchors may weigh more and should be handled using lifting equipment. Please refer to the order list for the accurate weight of each product.

13.1 Personal Protection

Always use gloves, a safety helmet, and safety shoes as a minimum requirement when operating the equipment. Keep hands and other body parts away from the lifting stand, lifting accessories, and the load during use.



13.2 Preparation of the product before use

13.2.1 Transport and Storage

Anchors should be transported and stored safely to prevent risks to personnel and nearby objects.

13.2.2 Unpacking

Remove the pallet and packaging protecting the anchors.

Cut the safety straps. The person unpacking should wear gloves, safety shoes, and safety glasses when cutting the straps.

13.2.3 Safe Disposal of Packaging Materials

All packaging used by Certex Denmark can be reused. Pallets and all wooden packaging can be reused or recycled.

All plastic, cardboard, and paper materials should be sent to the local recycling center.

If there are no local recycling facilities, the packaging should be returned to Certex Denmark for disposal at the customer's expense.

13.2.4 Preparatory Work Before Installation

After unpacking, visually inspect the anchors for any damage.

13.2.5 Installation and Assembly

The anchors are delivered ready for use.

13.2.6 Storage and Protection Between Periods of Normal Use

Inspect the anchors before each use and lift. Never use anchors or lifting accessories with visible defects such as wear, deformations, corrosion damage, etc.

Always store the lifting bar indoors, in a dry and ventilated area.

13.2.7 Provision of Information (Users, Operators, Service Experts)

All operators or individuals within the danger zone must receive information on operating the anchors and must be trained by the supervisor, familiarizing themselves with the product and its use before lifting operations commence.

Operators must be trained in the use of the lifting bar and all its functions and positioned to have a clear view of the entire lifting operation.

13.2.8 Placement of Instruction

All user manuals should always be stored together with the lifting bar.

14 Maintenance and inspection

- All maintenance must be performed when the Starcon lifting unit is unloaded.
- The Starcon lifting unit should be inspected and maintained to ensure it remains in proper condition during use.
- After each use, the Starcon lifting unit should be cleaned and inspected for any faults or deficiencies.
- If any faults are found, they must be rectified, or the Starcon lifting unit should be discarded.
- The Starcon lifting unit should always be stored in a dry and well-ventilated area.
- Any damaged, corroded, or worn-out Starcon lifting unit must be immediately taken out of service and marked not be used again.
- Equipment from Starcon should undergo at least one annual inspection by a qualified skilled person to inspect lifting equipment and cranes.

14.1 Maintenance Schedule



- Only original spare parts may be used, and they must be replaced by a trained individual.
- The annual inspection must be carried out by a qualified individual who has received the necessary training and certification for lifting equipment.
- All services must be documented, and the data must be stored.
- If there are any visual defects or if the labeling is not present on the lifting stand, the lifting stand must be marked as "out of service".

B Before use

A After use

M Monthly, or a maximum of 200 hours of usage.

Y Annually, or after a maximum of 2400 hours of use.

| Inspection | B | A | M | Y |
|---|---|---|---|---|
| Perform a visual inspection to check for signs of overload, deformation, damage, wear, and corrosion. | X | X | X | X |
| The equipment must undergo inspection. | | | X | |
| Ensure that the equipment is ready and clearly labeled. | X | | | X |
| Inspection should be carried out by a qualified individual with a report prepared. | | | | X |

Table 11 Maintenance schedule

15 Disposal / Recycling

This section describes the end of use for the product.

- End of use / Disposal The lifting points shall be sorted / scrapped as general steel scrap.
- The Starcon lifting and handling system should be sorted and disposed of according to appropriate material categories, including metal, plastic, etc.
- Certex can assist you with disposal if required.

16 Product data of Lifting socket solid materials

Figure 10 shows a measurement sketch for the Lifting socket solid material with labels for the respective dimensions.

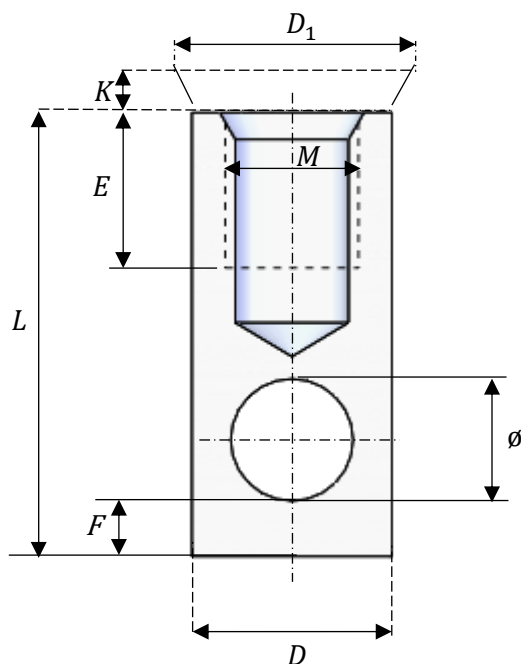

Figure 10 Lifting socket solid material sketch.

16.1 Technical data

Table 12 shows the dimensions of the various types of Lifting socket solid materials.

| Load group | Size | Anchor dia. D mm | Dia. pin ø mm | Anchor length L mm | Thread M mm | Thread length E mm | Hole distance F mm | Dia. nailling plate D ₁ mm | Nail thickness K mm |
|------------|---------|---------------------|------------------|-----------------------|----------------|-----------------------|-----------------------|--|------------------------|
| 0.4S | M10x40 | 16 | 9 | 42 | 10 | 21 | 5 | 58 | 10 |
| 0.5S | M12x40 | 18 | 11 | 40 | 12 | 14 | 5 | 58 | 10 |
| | M12x49 | 18 | 11 | 49 | 12 | 20 | 5 | | |
| 1.2S | M16x50 | 22 | 14 | 50 | 16 | 19 | 7 | 58 | 10 |
| | M16x56 | 22 | 14 | 56 | 16 | 23 | 7 | | |
| 2S | M20x68 | 28 | 16 | 68 | 20 | 28 | 9 | 58 | 10 |
| | M20x78 | 28 | 16 | 78 | 20 | 40 | 9 | | |
| | M20x87 | 28 | 16 | 87 | 20 | 45 | 9 | | |
| 2.5S | M24x80 | 32 | 21,5 | 80 | 24 | 35 | 13 | 58 | 10 |
| 4S | M30x103 | 40 | 22 | 103 | 30 | 45 | 15 | 58 | 10 |

Table 12 Lifting socket solid material dimension.

17 Product data of Lifting loop

Figure 11 shows a measurement sketch for lifting loop.

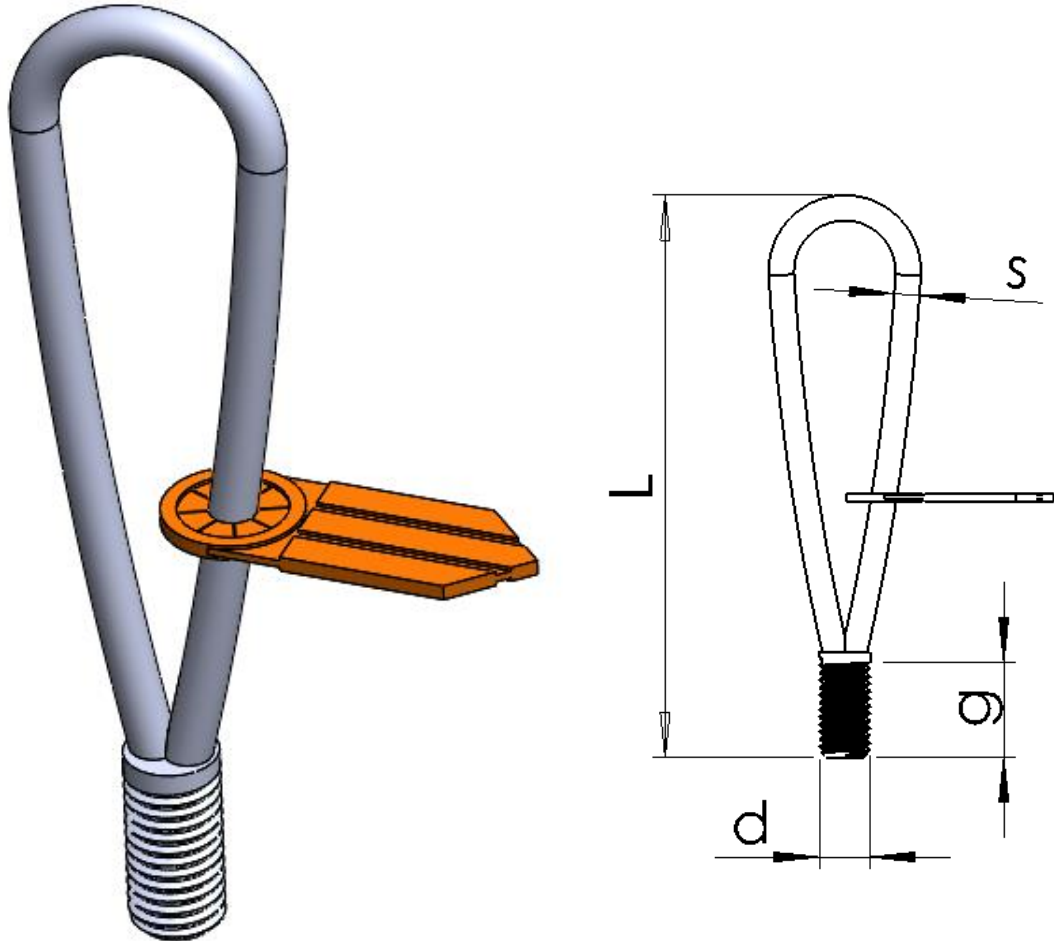

Figure 11 Universal lifter dimension sketch.

17.1 Technical data

Table 13 shows the dimensions of the various types of lifting loop

| Load group | Length of lifting loop <i>L</i> <i>mm</i> | Diameter of wire <i>s</i> <i>mm</i> | Thread <i>d</i> <i>mm</i> | Thread length <i>g</i> <i>mm</i> |
|------------|---|---|---------------------------------|--|
| 0.5S | 130 | 6 | 12 | 12,5 |
| 1.2S | 170 | 8 | 16 | 14 |
| 2S | 210 | 10 | 20 | 18 |
| 2.5S | 260 | 12 | 24 | 27 |
| 4S | 340 | 16 | 30 | 56 |

Table 13 Lifting loop dimension.

18 Product data of Alpha inclined pull lifting loop

Figure shows a measurement sketch for the Alpha inclined pull lifting loop.

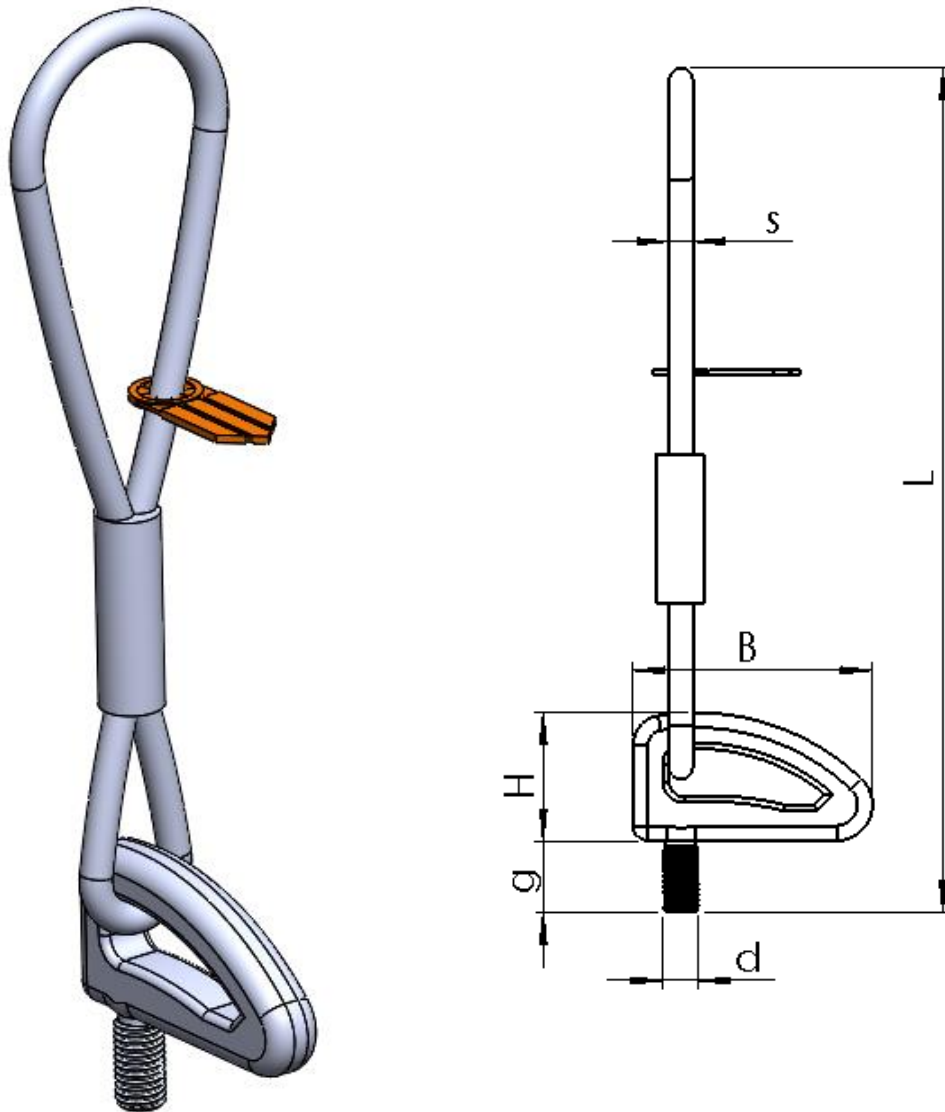

Figure Alpha inclined pull lifting loop dimension sketch.

18.1 Technical data

Table 14 shows the dimensions of the various types of Alpha inclined pull lifting loop

| Load group | Length of lifting loop <i>L</i> <i>mm</i> | Diameter of wire <i>s</i> <i>mm</i> | Ring width <i>B</i> <i>mm</i> | Ring height <i>H</i> <i>mm</i> | Thread <i>d</i> <i>mm</i> | Thread length <i>g</i> <i>mm</i> |
|------------|---|---|-------------------------------------|--------------------------------------|---------------------------------|--|
| 0.4S | 260 | 8 | 55 | 42 | 10 | 22 |
| 0.5S | 260 | 8 | 55 | 42 | 12 | 24 |
| 1.2S | 320 | 10 | 55 | 42 | 16 | 28 |
| 2S | 380 | 12 | 89 | 69 | 20 | 34 |
| 2.5S | 430 | 14 | 89 | 69 | 24 | 39 |
| 4S | 490 | 16 | 89 | 69 | 30 | 46 |

Table 14 Alpha inclined pull lifting loop dimension.

19 Product data of Goliath Lifting loop 40.8

Figure 12 shows a measurement sketch for the Goliath Lifting loop 40.8

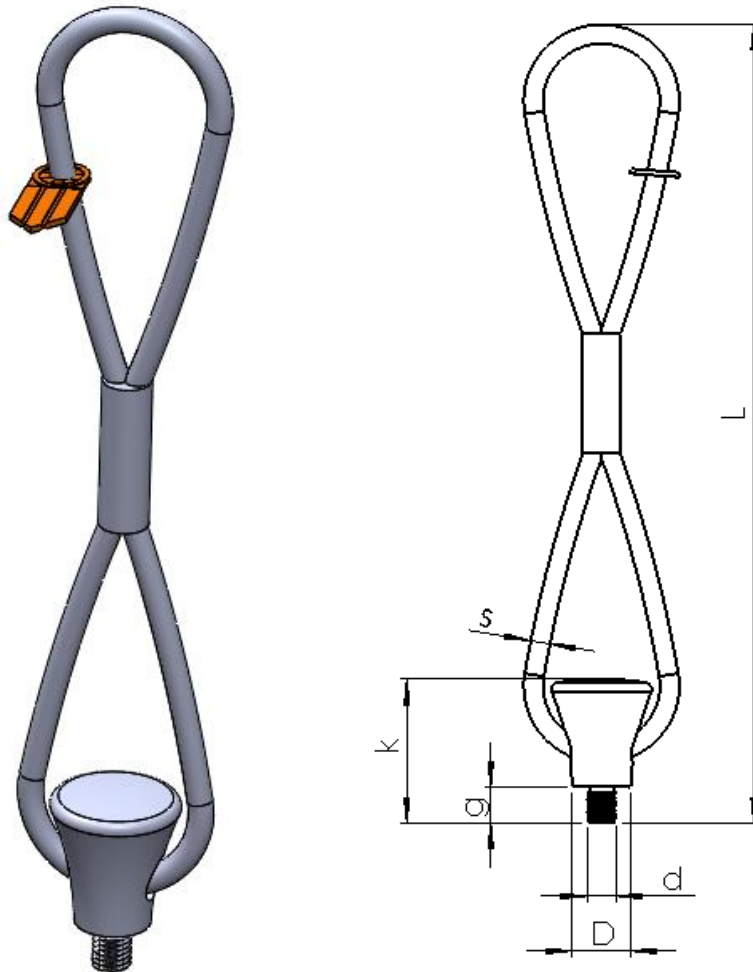

Figure 12 Goliath Lifting loop 40.8-dimension sketch.

19.1 Technical data

Table 15 shows the dimensions of the various types of Goliaths Lifting loop 40.8

| Load group | Length of lifting loop <i>L</i> <i>mm</i> | Diameter of wire <i>s</i> <i>mm</i> | Diameter of ring <i>D</i> <i>mm</i> | Ring height <i>k</i> <i>mm</i> | Thread <i>d</i> <i>mm</i> | Thread length <i>g</i> <i>mm</i> |
|------------|---|---|---|--------------------------------------|---------------------------------|--|
| 0.4S | 335 | 8 | 24 | 60 | 10 | 15 |
| 0.5S | 335 | 8 | 24 | 60 | 12 | 15 |
| 1.2S | 365 | 9 | 24 | 60 | 16 | 20 |
| 2S | 470 | 12 | 44 | 102 | 20 | 25 |
| 2.5S | 550 | 14 | 44 | 102 | 24 | 30 |
| 4S | 590 | 16 | 44 | 102 | 30 | 35 |

Table 15 Goliath lifting loop dimension.

20 Product data of nailing plates for Lifting socket solid materials

Figure 13 shows a measurement sketch for the nailing plates.

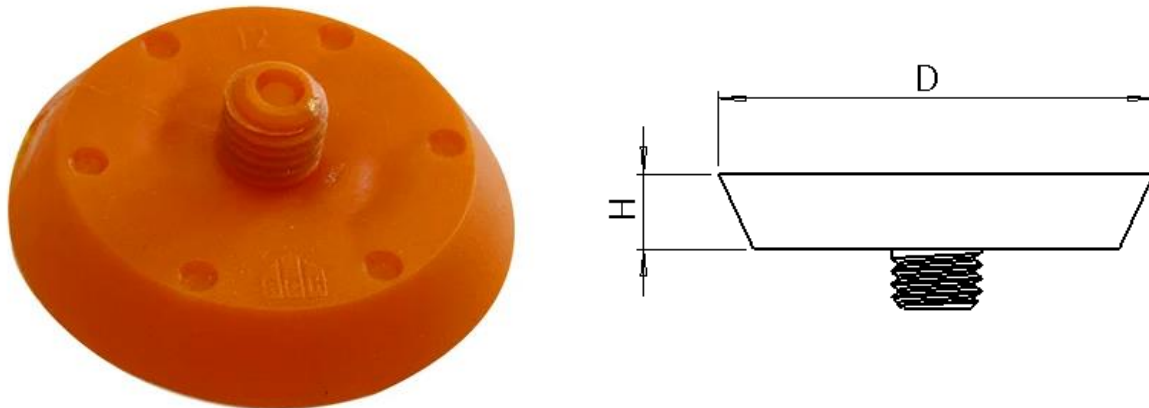

Figure 13 Nailing plates for Lifting socket solid materials.

20.1 Technical data

Table 16 shows the dimensions of the various types of the nailing plate used for casting of the transport anchors.

| Nailing plates Starcon Load group | D <i>mm</i> | H <i>mm</i> | Color |
|--------------------------------------|----------------|----------------|-------------|
| 0.4S | 58 | 10 | Yellow |
| 0.5S | 58 | 10 | Orange |
| 1.2S | 58 | 10 | Red |
| 2.0S | 58 | 10 | Light Green |
| 2.5S | 58 | 10 | Black |
| 4.0S | 58 | 10 | Dark Green |

Table 16 Dimension of nailing plate for Lifting socket solid material.

21 EC – Declaration of Conformity of the Machinery

This certificate meets the requirements of the Directive 2006/42/EC Annex II.

Manufacturer and responsible for compiling the technical documentation:

| | | | |
|----------|--|-----------|------------------------|
| Company: | CERTEX Danmark A/S | Tel. No.: | +45 74 54 14 37 |
| Address: | Trekanten 6-8 6500 Vojens Denmark | E-mail: | info@certex.dk |

The undersigned hereby declares that the below specified tool comply with the current safety and health rules and legislation within the European Union. If any changes are made on the tool without approval from the manufacturer, this Declaration no longer applies.

| | |
|--------------------------|--------------------------------------|
| Description: | Lifting socket solid material |
| Drawing No.: | XXXXXXXXXXXXXXXX |
| Serial No.: | XXXXXX |
| Lifting Capacity: | WLL pr unit |
| Own Weight: | Kg pr unit |

Is made in accordance with the following EC-directive;
2006/42/EC

The following standards have been used:
EN 13155+A2 : 2009

Date:

For CERTEX Danmark A/S

Our industries, products & services

At CERTEX Denmark, we are a secure and reliable total supplier and partner within lifting equipment. Below is an overview of the industries we service, our product range, and the services we offer."

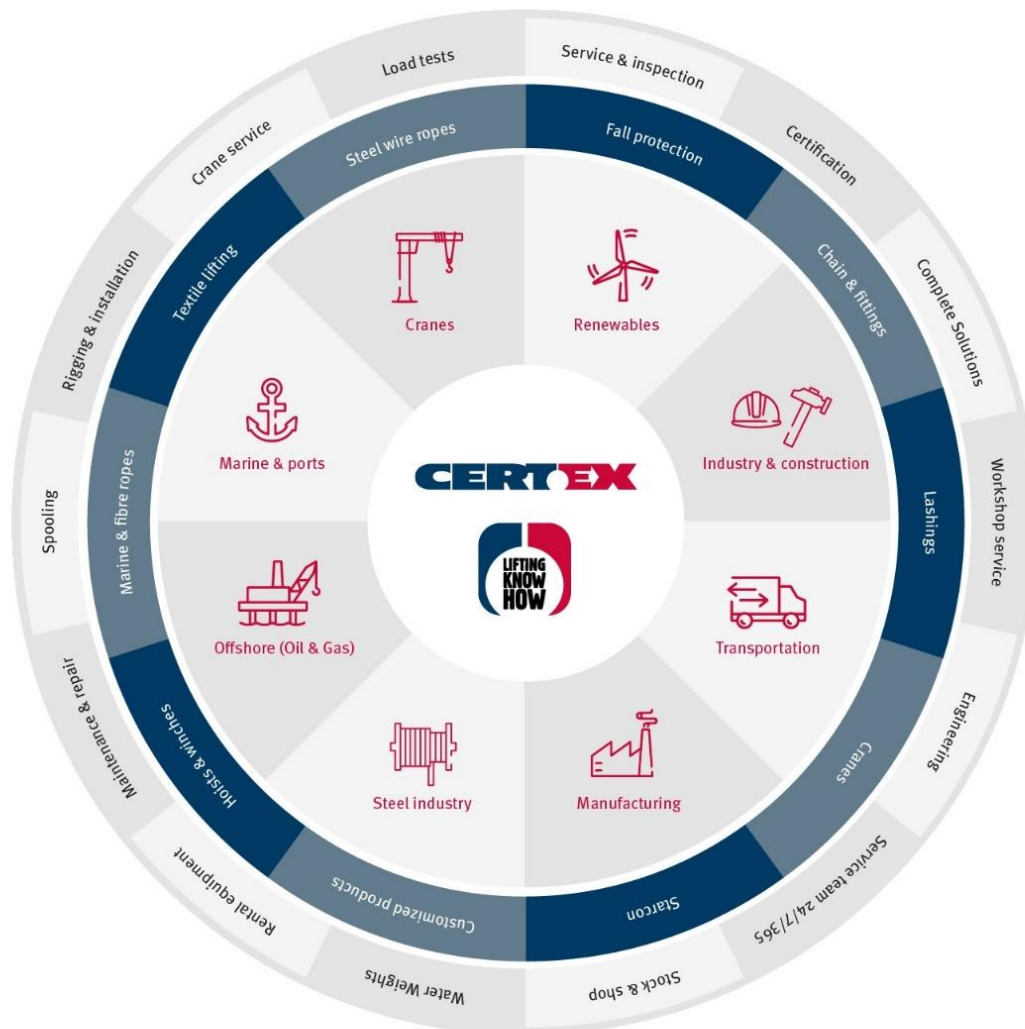

"

**Based on many years of experience
& know-how within lifting, load
tests & engineering, CERTEX
Denmark is your reliable partner &
supplier of steel wire, lifting
applications & related services."**