

# STARCON

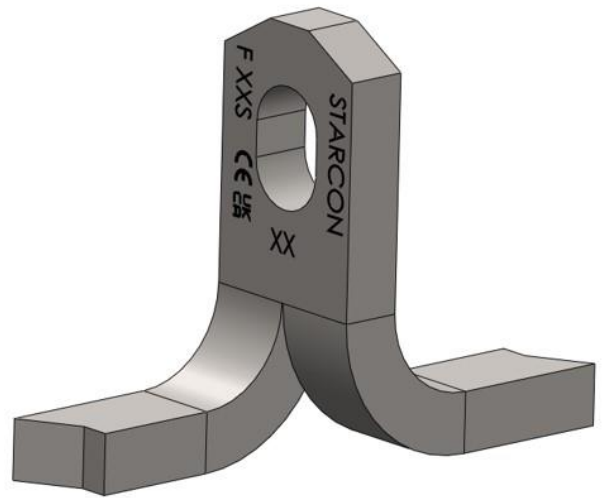

## STARCON

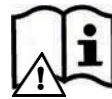

### STA F anchor system 2.5S to 10S

Lifting and handling systems for concrete elements.

User and design manual

## 1 Nomenclature

Symbol	Description	Unit
$\alpha$	Diagonal pull angle between sling and axial direction	°
$\beta$	Tilting angle between element and axial direction	°
$\gamma$	Turning angle between element and horizontal direction	°
°C	Temperature Celsius	°C
$\sigma_{ele}$	Concrete strength of the element at the time of lifting	MPa
$B$	Minimum plate thickness of a tile/slap/deck	mm
$COG$	Center of gravity	[-]
$d_s$	Diameter of the U-bar	mm
$d_{s1}$	Diameter diagonal pull bar	mm
$d_{s2}$	Diameter edge bar	mm
$d_{s3}$	Diameter edge bar around STA F	mm
$d_{bar}$	Bending diameter of the diagonal pull bar	mm
$F_S$	Load in diagonal direction	N
$F_Z$	Load in axial direction	N
$K$	Former spacing in the concrete element	mm
$l$	Length / height of the anchor	mm
$l_1$	Length u bar	mm
$l_{bar}$	Total link length of the diagonal pull bar	mm
$l_s$	Additional reinforcement bar length	mm
$o$	Distance between U-bars	mm
$S$	Load g symbol (STARCON)	-
$S_Z$	Distance between anchors	mm
$WLL$	Working Load limit	tons

Table 1 Nomenclature

## Starcon Precast Concrete Design & Lifting Manual

1	Nomenclature .....	1
2	Identification.....	2
3	Introduction Starcon STA anchor system 1.4S to 26S.....	3
4	Safety instructions before use .....	4
5	Advantages of the Starcon system. ....	4
6	Using the Starcon system.....	5
7	Safety factors for lifting systems.....	6
8	General information.....	7
9	Design method .....	8
10	Recommend support for STA near the wall in concrete elements.....	12
11	STA F anchors with standard reinforcement including, U-bar, and edge reinforcement.....	13
12	General safety information when using the Starcon system.....	15
13	Maintenance and inspection .....	17
14	Disposal / Recycling.....	18
15	Product data of STA F.....	18
16	Product data of ring clutch .....	19
17	Product data of ring clutch with wire .....	20
18	Product data of former for STA.....	21
19	EC – Declaration of Conformity of the Machinery .....	22

## 2 Identification

Table 2 provides insight into the revision number of this document. It facilitates tracking changes and ensuring version control for accurate referencing and updates.

Version	Responsible	Creator	Date	Comment
A	CERTEX Denmark	JLJ	18-09-2024	New documentation

Table 2 Revision table

## 3 Introduction Starcon STA anchor system 1.4S to 26S.

**Read this instruction manual before using the STA F. Incorrect use can cause injury or danger!**

*Safety is paramount when using lifting devices and equipment. Only trained individuals should operate them as per national law. Familiarize yourself with the instruction manual before use to ensure safe operation. Adhering to these guidelines reduces the risk of accidents. Consult relevant national regulations as they may supersede these instructions. All individuals involved with the equipment must read and understand this manual. Contact Certex for assistance or clarification. Always keep the manual with the product. Contact information is provided on the last page.*



### General concept of the use STA F:

The Starcon Lifting and Handling System consists of three key components: Starcon STA F, Starcon ring clutch, and Starcon former shown on Figure 1.

To ensure proper placement of the lifting unit in the finished concrete product, the head of the Starcon Lifting Anchor is assembled into a corresponding Starcon former before pouring. Once the concrete reaches a strength of at least 15 MPa, the former can be removed, and lifting can commence at the factory. At the installation site, lifting can only begin once the concrete has reached a strength of at least 25 MPa. Contact CERTEX DK for lower strength values. Lifting can be initiated by attaching the respectably rated ring clutch to the hole of the Starcon STA Anchor.

The Starcon lifting anchors and systems use the guidelines described in the German guidelines VDI/BV-BS 6205 and Technical Report CEN/TR 15728, combined with EN 13155-2009. This ensures the highest level of safety when using our products.

**Material:**

Steel.

**Surface treatment:**

Untreated or hot dip galvanized.

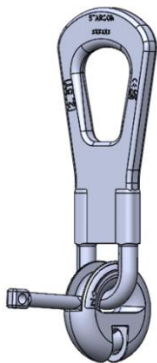

Lifting ring clutch

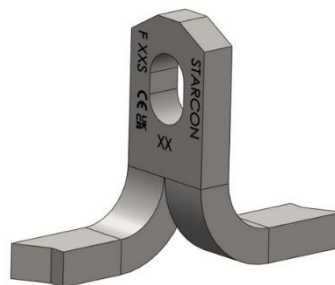

STA F

Figure 1 Starcon lifting system.

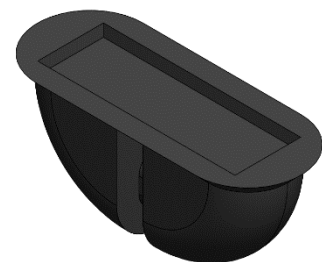

STA Former

### 4 Safety instructions before use



- The Starcon lifting anchor must only be installed in a Starcon former of the same rating.
- Starcon lifting anchors that are exposed of corrosion, or damaged must not be used.
- The Starcon lifting anchor must only be hoisted by a lifting unit of the same size.
- The Starcon lifting and handling system must not be used to lift more than the specified load.
- The Starcon lifting and handling system must not be used for personnel lifting.
- The Starcon products are designed for one-time lifting only.
- The Starcon lifting system must only be used by skilled, trained employees.
- A lifting accessory used with the ring clutch must be correctly marked and approved for lifting.
- Before use, check the weather conditions. Never operate the system if there is a likelihood of lightning in the area and avoid use in extreme weather conditions such as storms, heavy rain, or snowing.
- The concrete safety factor assumes a factory production control complying with EN13369. If these requirements are not fulfilled, a safety factor of  $\gamma = 2,5$  shall be used.
- All relevant concrete failure modes shall be verified by the pre casting manufacturer of the concrete elements; the different failure modes and verification methods are specified in EN13155 (Annex H).

### 5 Advantages of the Starcon system.

The Starcon system offers immediate assembly and release options for the lifting ring clutch, enabling precast concrete units to be handled quickly, safely, and economically, as shown in Table 3. A self-locking lifting ring clutch prevents accidental release. With the Starcon systems, time-consuming screw connections and wires prone to wear are avoided. Due to the lifting ring clutch high robustness, they can be used reliably for many years.

The Starcon system is available in load group 1.4S to 26S. The lifting ring clutch rotates freely around the anchor's axis, and the unique geometry of the system means the anchors can bear their full load even if they pull perpendicular to the anchor's axis.

The system's efficiency has been proven through many years of successful use and numerous laboratory tests. Components are regularly tested during production and clearly marked with the maximum load. The lifting ring clutch is individually tested and comes with a traceability batch code.

#### 5.1 Note

The information in this manual is for guidance only, and the use of the manual does not in any way exempt the manufacturer from ensuring that the chosen lifting system is suitable for the intended purpose. The information and data listed in this manual only refer to original Starcon products supplied by *CERTEX DANMARK A/S*.

## 6 Using the Starcon system

The Starcon system comprises a wide range of anchors in a load group from 1.4 to 26S per anchor with various lengths. The principle for using the system is the same for the entire range. The Starcon system consists of the following three main components:

### 6.1 Starcon Anchor

The Starcon anchor is a steel component designed for embedding, featuring a specially engineered foot for secure anchoring in hardened concrete. The Starcon anchor, which is plate-shaped, connects to a Starcon lifting ring clutch for lifting purposes. Each Starcon anchor is clearly labeled with its size (e.g., 2.5S) and is available in various lengths. They undergo sample testing for defects, dimensional deviations, and tensile strength, ensuring a minimum safety factor of 3:1 for metallic failure.

### 6.2 Starcon Former

The former are soft PVC components used for embedding an anchor in wet concrete. The anchor head is placed in the former, which can then be bolted to the formwork. After the unit is cast and hardened, the former is removed, revealing the anchor head seated in a semi-spherical depression in the concrete. Each former can be used for multiple castings if cleaned and lubricated after each use.

*The formers are also available in a steel version, with rubber material.*

### 6.3 Starcon Lifting ring clutch.

The Starcon ring clutch is a specially designed component with a pin-shaped claw that grips the top hole of the Starcon STA anchor. Starcon ring clutches are tested to twice the allowable load, and all test results are recorded. Each Starcon ring clutch is marked with an article number, identification number, and maximum working load with a safety factor of 4:1. A certificate is issued for each delivery.

An additional safety measure is that the Starcon system is available in several non-compatible load groups. It is not possible to incorrectly assemble components from different load groups, thus avoiding failure of the lifting arrangement.

## 6.4 Starcon Ring clutch assembly instructions.

The Starcon Ring clutch system enables efficient handling of flat cast concrete elements. To secure the ring clutch, insert it into the concrete recess and tighten the locking bolt manually. The system allows safe lifting in any direction, up to 60° vertically and 90° sideways, see Table 3. To remove the clutch, open the locking bolt manually.

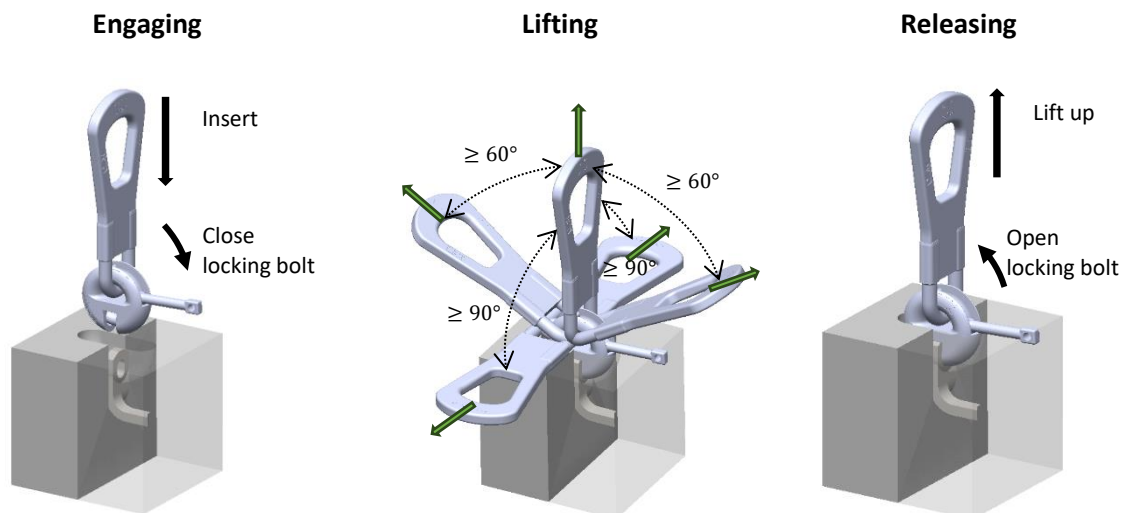

Insert the ring clutch into the concrete recess and manually close the locking bolt by sliding it to its limit position. Once secured, you can begin the lifting process.

The ring clutch is designed to handle loads from any direction, provided the load limits of the anchors are not exceeded. When using a spreader beam, it is permissible to apply an angled pull of up to 60°. And up to 90° to the sides.

Manually retract the pin to enable the removal of the ring clutch.

Table 3 The connection between the Starcon ring clutch and Starcon STA anchor is fast and easy.

## 7 Safety factors for lifting systems

For the calculations of the lifting system, the following safety factors shown in Table 4 have been applied to ensure its reliability and safety. These factors, in accordance with the recommendation of EN13155, have been carefully selected as guidelines to ensure optimal safety during the system's operation.

Failure safety factors	
Steel failure of anchors	$SF_{Steel} = 3$
Concrete pull out failure	$SF_{concrete} = 2,5$
Failure in the ring clutch	$SF_{Link} = 4$

Table 4 Failure safety factors

## 8 General information

This section provides essential details on the Starcon lifting anchor systems, offering clarity and guidance for safe and efficient usage.

### 8.1 Marking on the anchor

Each anchor is clearly labeled with its load capacity, length, and manufacturer's identification, ensuring easy and secure identification of the systems, even post-installation show on Figure 2.

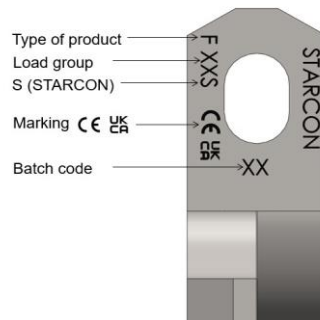

Figure 2 Marking on top of the STA F.

### 8.2 Guidelines for Anchor Selection

When selecting anchors, it's essential to consider various factors to ensure safety and effectiveness. Tables provided contain crucial information such as maximum load capacities, edge distances, and installation values for different anchor types. Key points to consider:

- Weight of the precast element.
- The number of anchors.
- How the anchors are arranged.
- The load-bearing capacity of the anchors
- Sling handling angle.
- The diagonal pull properties of the anchors.
- Environmental impact at the use.

### 8.3 Guidelines for installation

For the Starcon lifting anchor systems to be appropriately installed, it is imperative to ensure compliance with specific technical criteria and prerequisites:

- Adherence to load capacity specifications of the anchor.
- Maintaining appropriate edge spacing.
- Ensuring the concrete grade is suitable.
- Verifying alignment with the load direction.
- Additional reinforcement requirements.

### 8.4 Guideline for load capacity

Load capacity of an anchor relies on several factors:

- The strength of the concrete at the moment of lifting, as determined by a cube-test with dimensions of 15 × 15 × 15 cm.
- The length of the anchor.
- The spacing between the anchor and the edges, both axially and along the edge.
- The direction of the applied load.
- The arrangement of reinforcement within the concrete structure.



## 9 Design method

This section covers the design method for lifting operations as well as illustrations of various lifting techniques. It describes when the different types of lifts occur, including axial lifting, diagonal lifting, tilting, and rotation of elements. Additionally, the casting process is discussed, including the transfer of load to the concrete using the anchor base, and the importance of correctly placing formwork and anchors during casting to avoid errors and risks. Warnings are given regarding the correct size of formwork and the risk of errors with incorrect sizes, which can lead to potentially dangerous situations.

### 9.1 Illustration of lifting methods

Figure 3 shows a description of when the different types of lifts occur:

- **Axial pull:** occurs in the same direction as the pulling force and happens within the range of  $0^\circ \leq \alpha \leq 10^\circ$ .
- **Diagonal pull:** occurs when slings/chains are angled between  $10^\circ \leq \alpha \leq 60^\circ$  relative to the lift.
- **Tilting:** occurs when the object needs to rotate around its COG on the short side of the element.
- **Turning:** occurs when the object needs to rotate around its COG on the long side of the element.

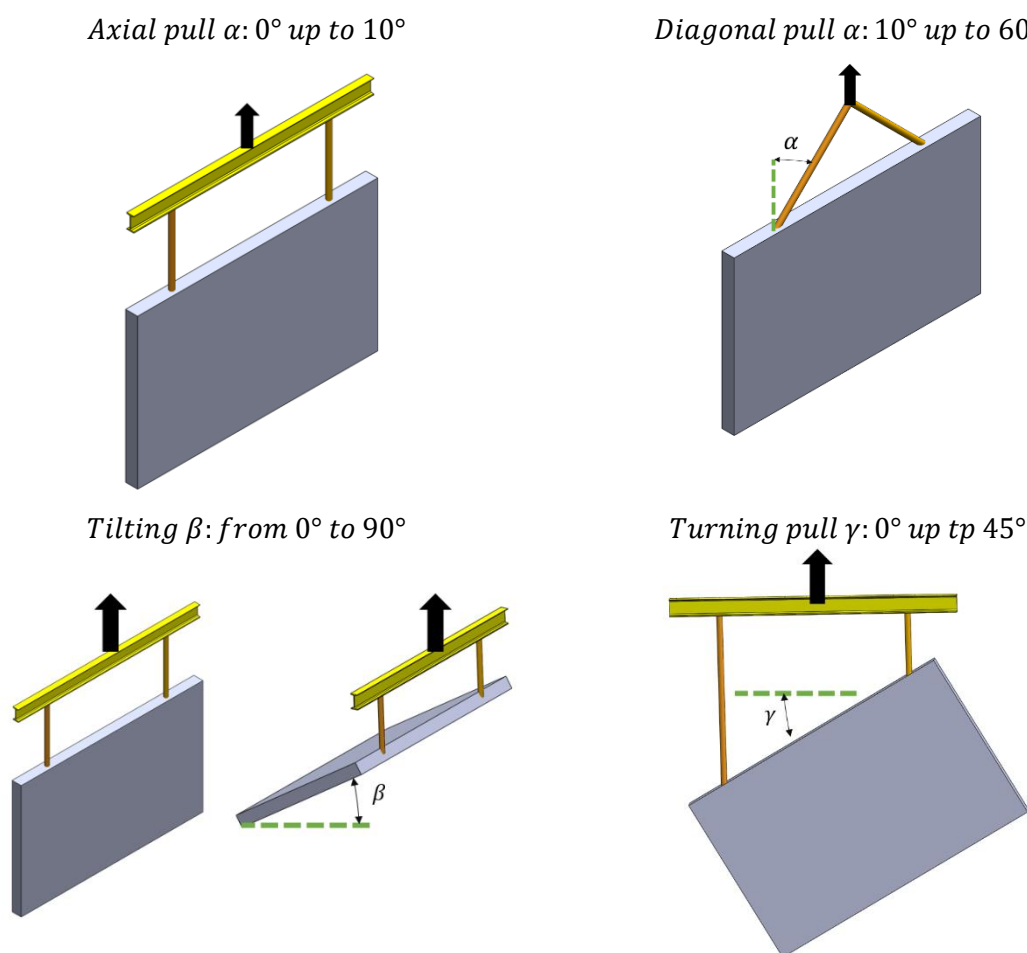

Figure 3 Lifting methods.

## 9.2 Load Transfer with Anchor Casting

Load transfer to the concrete is made easier by the anchor foot, which means it can handle heavy loads even with short anchors shown on Figure 4. However, with very thin elements, these concentrated loads can cause lateral spalling because of the strong pulling forces. The concrete must withstand a minimum resistance of 2.5 units before experiencing structural failure.

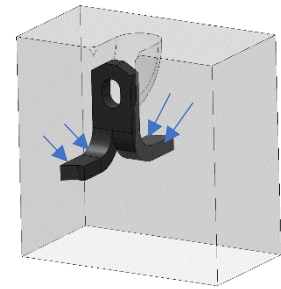

Figure 4 Load transfer.

### 9.2.1 Correct placement of former and anchors during casting.

Caution: If the form is too small, it won't be compatible with the lifting equipment later. Conversely, if the recess block is too large, attaching the lifting equipment correctly will be impossible, increasing the risk of the lifting ring clutch slipping out. This could lead to premature anchor failure and the subsequent collapse of the construction element. Always ensure the form size matches the identified appropriate size. Figure 5 illustrates the correct placement of the former in wet concrete to ensure optimal anchorage strength for the anchor.

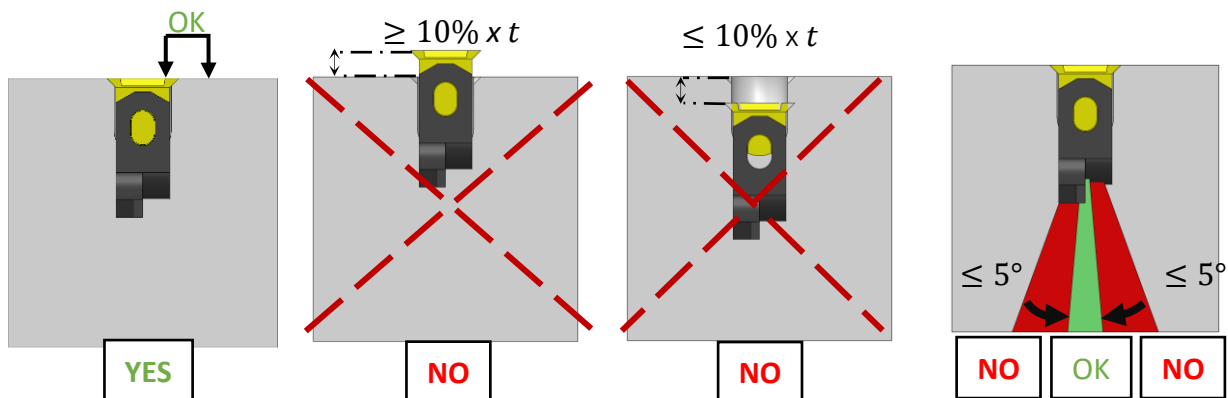

Figure 5 Correct placement of former.

Spread anchors and two-hole anchors should only be installed in thin-walled materials. The flat piece of steel must be positioned at a right angle to the slab to ensure proper installation and stability.

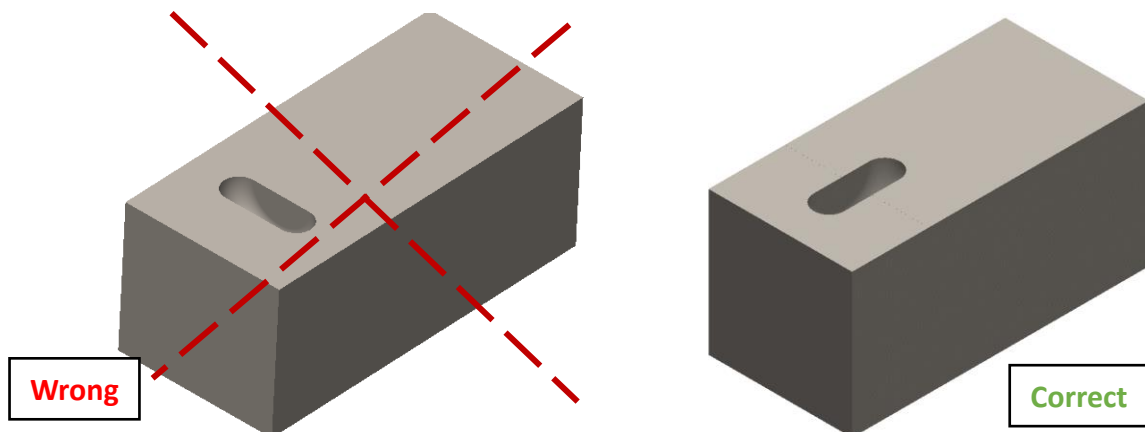

Figure 6 Correct placement of former direction in the wall.

## 9.3 Calculate load cases of removing from formwork and transport.

To ensure proper anchoring, each anchor must consider several factors: weight of the element, adhesion to the mold, shock load, sling angle, and the number and position of the anchors.

When lifting a concrete unit from a form, consider the adhesion factor between the concrete and the mold. For complex shapes, adhesion can increase anchor load, especially when concrete strength is at its lowest. Calculate the total weight of the elements in tons, including all equipment and accessories attached to the device.

### 9.3.1 Load case removing the formwork and transport of the element.

The tension force  $F_A$  in each the anchor:

1. Load case when removing the element from the formwork: 
$$F_A = \frac{(F_Z + S * P_a) * F_S}{n}$$

2. Load Case during transport lifting of the element. 
$$F_A = \frac{F_Z * F_S * \varphi_{dyn}}{n}$$

Where,

- $F_Z$ : Weight of the concrete element in Tons (*tonne*)
- $S$ : Surface area of the mould in contact with the fresh concrete ( $m^2$ )
- $P_a$ : Adhesion factor between the pouring box and concrete (See Table 6)
- $F_S$ : Sling angle factor (See Table 5)
- $n$ : Number of load-bearing anchors in the element.
- $\varphi_{dyn}$ : Dynamic factor of the element under transport

### 9.3.2 Sling angle factor ( $F_S$ )

The illustration in Figure 7 provides a visual explanation of how to measure the sling angle. Referencing Table 5, you can find the sling factor corresponding to the measured angle.

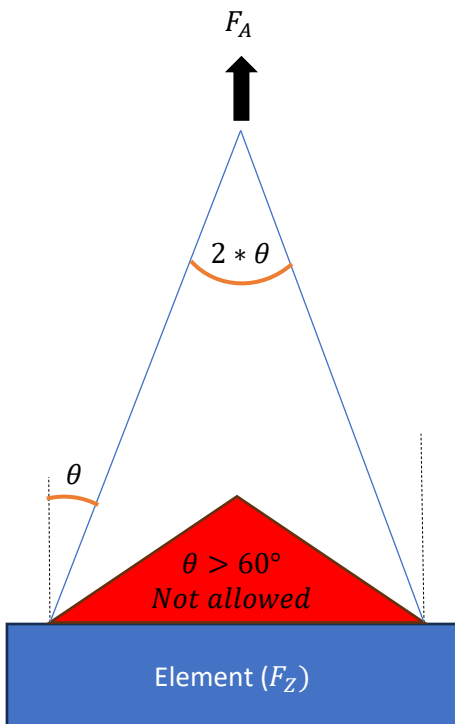

Figure 7 Sling angle factor illustration.

Sling angle degree ( $\theta$ )	Sling factor ( $F_S$ )
0°	1
10°	1,02
20°	1,07
30°	1,16
45°	1,41
60°	2

Table 5 Sling angle factor

### 9.3.3 Adhesion to formwork factors ( $Pa$ )

Adhesion factor between the pouring box and concrete is shown in Table 6.

Mould type	Adhesion ( $\frac{\text{tonnes}}{\text{m}^2}$ )
Lubricated steel form work	$Pa = 0,1$
Varnished timber formwork	$Pa = 0,2$
Rough formwork	$Pa = 0,3$

Table 6 Adhesion factor to formwork

### 9.3.4 Dynamic factors ( $\varphi_{dyn}$ )

If the concrete unit is handled or transported by mechanical equipment, it is exposed to shock/impact from gripping and transport over uneven ground. This factor can increase the anchor load several times its own weight. The correct load can be determined by adding the dynamic factor  $\varphi_{dyn}$  shown in Table 7

Lifting condition	Dynamic load factor
Static crane, rope speed <90 m/min	1
Static crane, rope speed >90 m/min	1,3
Lift and transport with mobile crane on smooth ground	1,75
Lift and transport with mobile crane on uneven ground	2,5
Transport with forklift or excavator over uneven ground	4

Table 7 Dynamic factor

### 9.3.5 The number and position of lifting points

The effective load carried by each anchor is typically calculated by dividing the total weight by the number of load-bearing anchors. However, this calculation assumes equal load distribution among all anchors. If the load distribution is unequal, the load to be carried by each anchor should be determined using static calculations as shown in Figure 8.

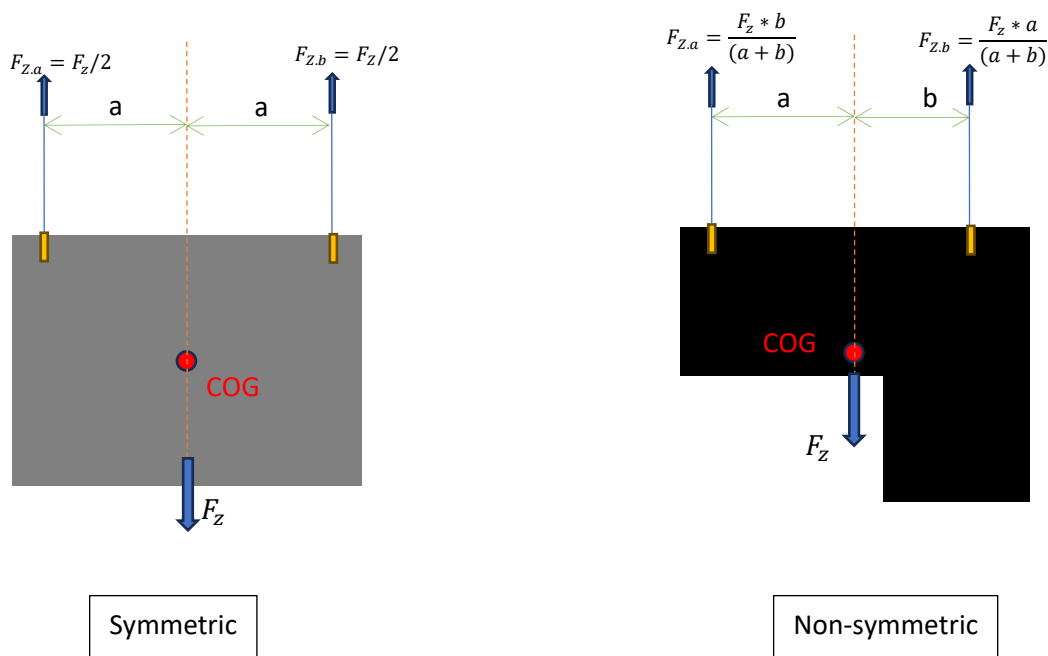

Figure 8 Calculation symmetric and non-symmetric loading element.

## 10 Recommend support for STA near the wall in concrete elements.

Figure 9 shows how to correctly position the reinforcement mesh inside the element. It highlights the importance of placing edge reinforcement closely around the anchor points for optimal strength. Additionally, it demonstrates the U - bars around the anchors and the correct placement of diagonal pull bars to effectively support the anchor and the opposite face during lifting or pulling operations.

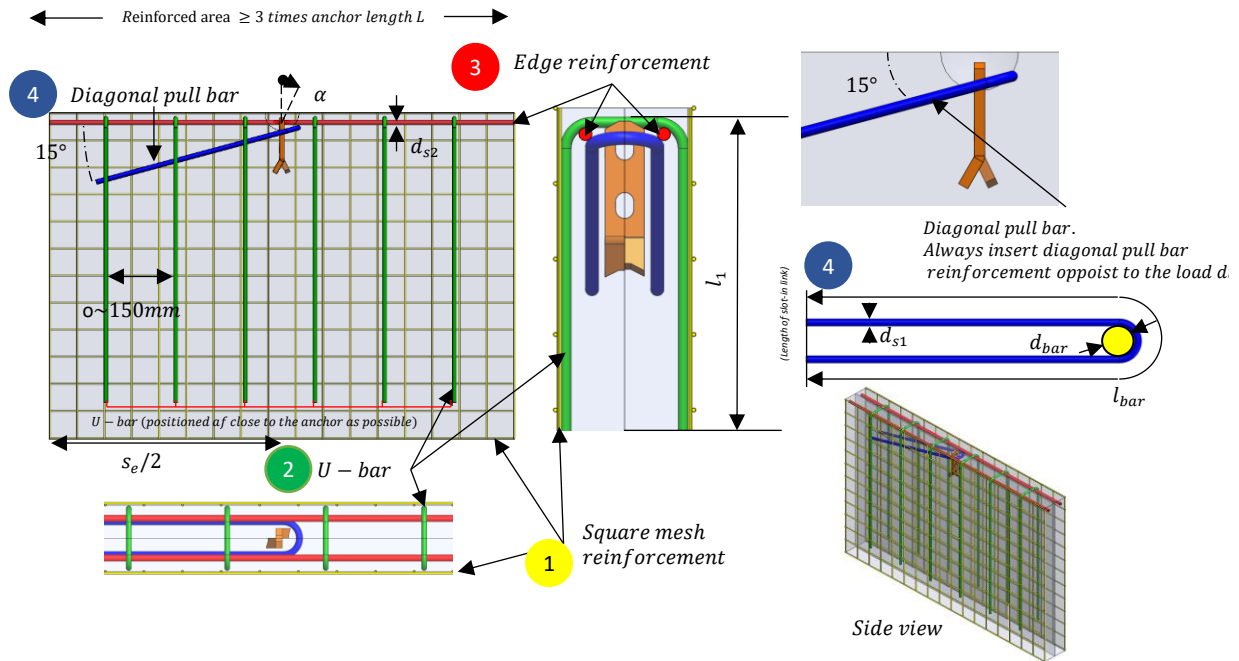

Figure 9 Reinforcement in the concrete wall.

Table 8 provides a detailed description of the correct placement of mesh and reinforcement within the concrete for each anchor type.

Load class lifting clutch	Load group	① Square mesh reinforcement  $mm^2/m$	② U-Bar			③ Edge reinforcement both sides  $d_{s2}$ mm	④ Diagonal pull bar ①		
			For pull > 30° [α]				$d_{s1}$ mm	$d_{bar}$ mm	$l_{bar}$ mm
			pcs.	$d_s$ mm	$l_1$ mm				
2.5S	1.3S	2 x 131	4	Ø6	400	Ø8	Ø6	47	900
	2.5S		4	Ø8	600				
5S	5.0S	2 x 131	4	Ø10	800	Ø12	Ø12	53	1550
10S	7.5S	2 x 188	4	Ø10	800	Ø12	Ø14	71	2000
	10.0S		6	Ø10	1000				
26S	14.0S	2 x 377	6	Ø10	1000	Ø14	Ø20	116	2600
	22.0S		8	Ø10	1200				

① There is no requirement for diagonal tension reinforcement in concrete with the following strength:

Concrete compressive strength ( $\sigma_{ele}$ ) is  $\geq 15$  N/mm<sup>2</sup> and 3 times the minimum wall thickness,

Concrete compressive strength ( $\sigma_{ele}$ ) is  $\geq 25$  N/mm<sup>2</sup> and 2.5 times the minimum wall thickness,

Concrete compressive strength ( $\sigma_{ele}$ ) is  $\geq 35$  N/mm<sup>2</sup> and 2 times the minimum wall thickness.

(!) The reinforcement for diagonal loads needs to be positioned near the recess former, ensuring complete contact with the anchor during installation

$\sigma_{ele}$  Stands for concrete element strength at time of lifting.

**Disclaimer: The table serves solely as a guideline. For accurate guidance and calculations, please contact [www.Certex.dk](http://www.Certex.dk).**

Table 8 Reinforcement data for elements

## 11 STA F anchors with standard reinforcement including, U-bar, and edge reinforcement.

This description aims to provide an understanding of the capacity of these anchors within structures with special reinforcements shown on Figure 10, including the following components, Reinforcement mesh, U-Bar, edge reinforcement and diagonal pull bars only if,  $\alpha > 30^\circ$ . The table below provides insights that can contribute to an accurate evaluation of the suitability of lifting concrete elements in various scenarios. When loads are directed towards the edge of the element, insert diagonal pull reinforcement as used for spreading or two-hole anchors. (see Figure 9 and Table 8).

**Reinforcement requirements from Table 8**

- ① Reinforcement mesh
- ③ Edge reinforcement
- ④ Diagonal pull bars, only if  $\alpha > 30^\circ$

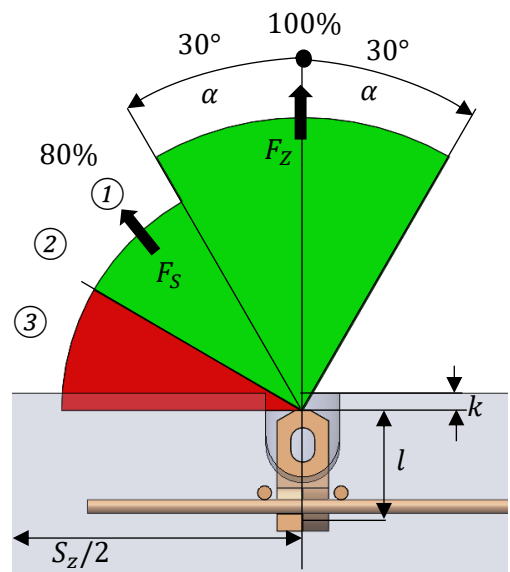
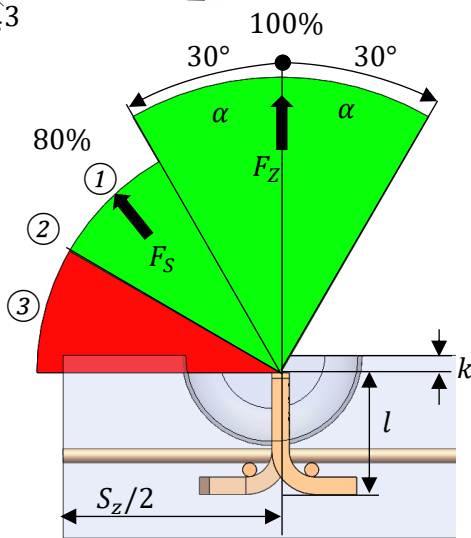
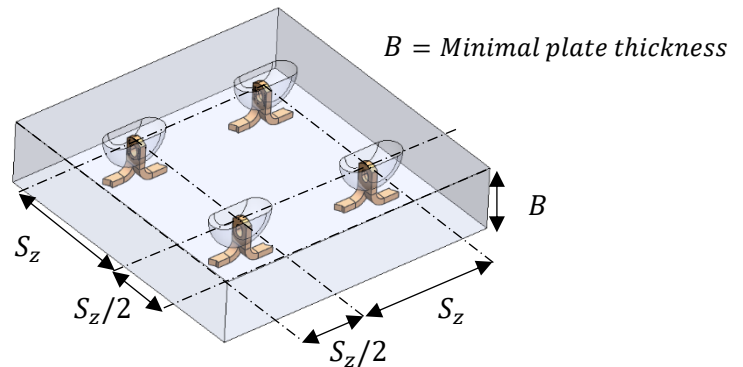
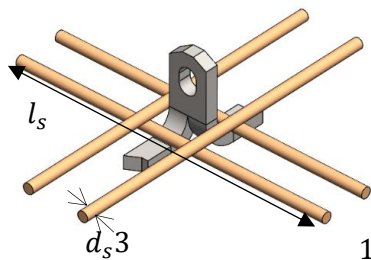

- (1) Diagonal tension at  $30^\circ \leq \alpha \leq 60^\circ$  without reinforcement is only allowed if:
  - Concrete compressive strength ( $\sigma_{ele}$ ) is  $\geq 15 \text{ N/mm}^2$  and 3 times the minimum wall thickness,
  - Concrete compressive strength ( $\sigma_{ele}$ ) is  $\geq 25 \text{ N/mm}^2$  and 2.5 times the minimum wall thickness,
  - Concrete compressive strength ( $\sigma_{ele}$ ) is  $\geq 35 \text{ N/mm}^2$  and 2 times the minimum wall thickness.
- (2) With concrete strength  $\sigma_{ele} \geq 23 \text{ N/mm}^2$ ,  $F_s$  can be taken as 100%
- (3) Diagonal tension with cable/chain spreading  $\alpha > 60^\circ$  is not permitted.

Figure 10 Reinforcement requirements for STA F anchors.

## Lifting an element

Table 9 provides information to assist in determining the appropriate anchors for lifting concrete elements under various loading conditions.

The following boundary conditions are utilized for the calculation:

- **1 anchor** symmetrically positioned to the center of gravity.
- **Dynamic factor** (site handling)  $\Gamma_{dyn} = 1.3$
- **Formwork adhesion** is not considered.

Load class lifting ring clutch	Load group	Anchor length.  L  mm	Min. wall thickness  B  mm	Additional reinforcement B500B		Load capacity [Ton] for Axial pull, Diagonal Pull and transverse pull at concrete strength $\sigma_{ele}$			Min. distance between anchors.  S <sub>Z</sub>  mm
				$d_{s3}$	$l_s$	15 N /mm <sup>2</sup>	25 N /mm <sup>2</sup>	35 N /mm <sup>2</sup>	
				mm	mm	mm	mm	mm	
2.5S	2.5S	70	105	8	300	1.72	1.72	1.72	240
5.0S	5S	120	160	12	500	3.25	3.25	3.25	390
10.0S	7.5S	170	215	14	600	5.17	5.17	5.17	510
	10S	200	245	14	600	6.35	6.35	6.35	600
26.0S	12.5S	220	265	16	750	7.96	7.96	7.96	660
	17S	270	315	16	900	9.63	9.63	9.63	810
	22S	310	355	20	1100	12.6	12.6	12.6	930

$\sigma_{ele}$  Stands for concrete element strength at time of lifting.

*Disclaimer: The table serves solely as a guideline. For accurate guidance and calculations, please contact [www.Certex.dk](http://www.Certex.dk).*

Table 9 Reinforcement requirements for STA F anchors.

## 12 General safety information when using the Starcon system.

General safety information when using the Starcon system.



- Ensure that the marking on the Starcon lifting unit always points in the direction of pull during lifting.
- The lifting machine must be approved to lift at least the maximum applied load + the weight of the Starcon lifting and handling system + any hoisting accessories.
- Lifting movements must be smooth; no sudden or abrupt changes in direction with the lifting machine should be made during a lifting operation, as this can lead to pendulum movements of the load, causing crushing hazards or dropping of the load.
- Where there is a risk of crushing between the load and objects, building parts, machinery, etc., the operator must not be in the danger zone.
- The operator's work area must be flat and free of obstacles that could pose a tripping hazard.
- When depositing the load, the operator must ensure this accepts on a flat and stable surface.
- Only when the load has been deposited and secured the Starcon lifting unit is completely unloaded may it be released and lifted free.
- Before each lift, ensure that both the Starcon lifting unit and the Starcon lifting anchor embedded in the concrete product are free from dirt that could reduce grip.
- Never insert arms or feet under a concrete product.
- Concrete products must never be dragged, only lifted.
- No modifications to the Starcon lifting and handling system may be made without written permission from the manufacturer.
- The operator must always ensure that the connection between the lifting machine and/or any hoisting accessories and the Starcon lifting unit is correct and secured against unintentional detachment.
- The operator must always ensure that the connection between the Starcon lifting unit and the Starcon lifting anchor is correct and secured against unintentional detachment.
- Keep a safe distance and never walk under a suspended load.
- Use gloves, safety shoes and other PPE when handling.
- Never use a Starcon lifting and handling system that has visible defects such as wear, deformations, rust damage, etc.
- Most anchors are designed to be easily handled during installation without the need for lifting equipment. However, some anchors may weigh more and should be handled using lifting equipment. Please refer to the order list for the accurate weight of each product.

### 12.1 Personal Protection

Always use gloves, a safety helmet, and safety shoes as a minimum requirement when operating the equipment. Keep hands and other body parts away from the lifting stand, lifting accessories, and the load during use.





## 12.2 Preparation of the product before use

### 12.2.1 Transport and Storage

Anchors should be transported and stored safely to prevent risks to personnel and nearby objects.

### 12.2.2 Unpacking

Remove the pallet and packaging protecting the anchors.

Cut the safety straps. The person unpacking should wear gloves, safety shoes, and safety glasses when cutting the straps.

### 12.2.3 Safe Disposal of Packaging Materials

All packaging used by Certex Denmark can be reused. Pallets and all wooden packaging can be reused or recycled.

All plastic, cardboard, and paper materials should be sent to the local recycling center.

If there are no local recycling facilities, the packaging should be returned to Certex Denmark for disposal at the customer's expense.

### 12.2.4 Preparatory Work Before Installation

After unpacking, visually inspect the anchors for any damage.

### 12.2.5 Installation and Assembly

The anchors are delivered ready for use.

### 12.2.6 Storage and Protection Between Periods of Normal Use

Inspect the anchors before each use and lift. Never use anchors or lifting accessories with visible defects such as wear, deformations, corrosion damage, etc.

Always store the lifting bar indoors, in a dry and ventilated area.

### 12.2.7 Provision of Information (Users, Operators, Service Experts)

All operators or individuals within the danger zone must receive information on operating the anchors and must be trained by the supervisor, familiarizing themselves with the product and its use before lifting operations commence.

Operators must be trained in the use of the lifting bar and all its functions and positioned to have a clear view of the entire lifting operation.

### 12.2.8 Placement of Instruction

All user manuals should always be stored together with the lifting bar.

## 13 Maintenance and inspection

- All maintenance must be performed when the Starcon lifting unit is unloaded.
- The Starcon lifting unit should be inspected and maintained to ensure it remains in proper condition during use.
- After each use, the Starcon lifting unit should be cleaned and inspected for any faults or deficiencies.
- If any faults are found, they must be rectified, or the Starcon lifting unit should be discarded.
- The Starcon lifting unit should always be stored in a dry and well-ventilated area.
- Any damaged, corroded, or worn-out Starcon lifting unit must be immediately taken out of service and marked not be used again.
- Equipment from Starcon should undergo at least one annual inspection by a qualified skilled person to inspect lifting equipment and cranes.

### 13.1 Maintenance Schedule



- Only original spare parts may be used, and they must be replaced by a trained individual.
- The annual inspection must be carried out by a qualified individual who has received the necessary training and certification for lifting equipment.
- All services must be documented, and the data must be stored.
- If there are any visual defects or if the labeling is not present on the lifting stand, the lifting stand must be marked as "out of service".

- B** Before use
- A** After use
- M** Monthly, or a maximum of 200 hours of usage.
- Y** Annually, or after a maximum of 2400 hours of use.

Inspection	B	A	M	Y
Perform a visual inspection to check for signs of overload, deformation, damage, wear, and corrosion.	X	X	X	X
The equipment must undergo inspection.			X	
Ensure that the equipment is ready and clearly labeled.			X	X
Inspection should be carried out by a qualified individual with a report prepared.				X

Table 10 Maintenance schedule

## 14 Disposal / Recycling

This section describes the end of use for the product.

- End of use / Disposal The lifting points shall be sorted / scrapped as general steel scrap.
- The Starcon lifting and handling system should be sorted and disposed of according to appropriate material categories, including metal, plastic, etc.
- Certex can assist you with disposal if required.

## 15 Product data of STA F

Figure 11 shows a measurement sketch for the STA F with labels for the respective dimensions.

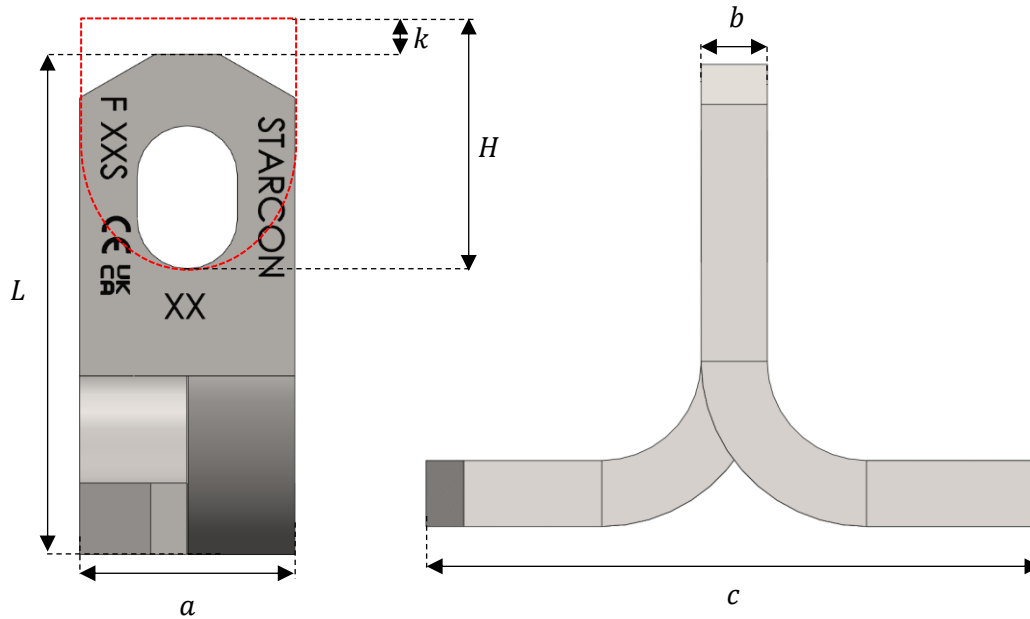

Figure 11 STA F sketch.

### 15.1 Technical data

Table 11 shows the dimensions of the various types of STA F.

Load class lifting clutch	Load group	a mm	b mm	c mm	k mm	H – former height mm	L - Anchor length mm
2.5S	2.5S	30	10	94	10	45	70
5S	5.0S	40	15	105	10	59	125
10S	7.5S	60	16	120	15	85	170
	10S	60	20	120	15	85	200
26S	12.5S	80	16	200	15	118	220
	17S	80	20	200	15	118	270
	22S	90	28	200	15	118	310

Table 11 STA F dimension.

## 16 Product data of ring clutch

Figure 11 shows a measurement sketch for the ring clutch.

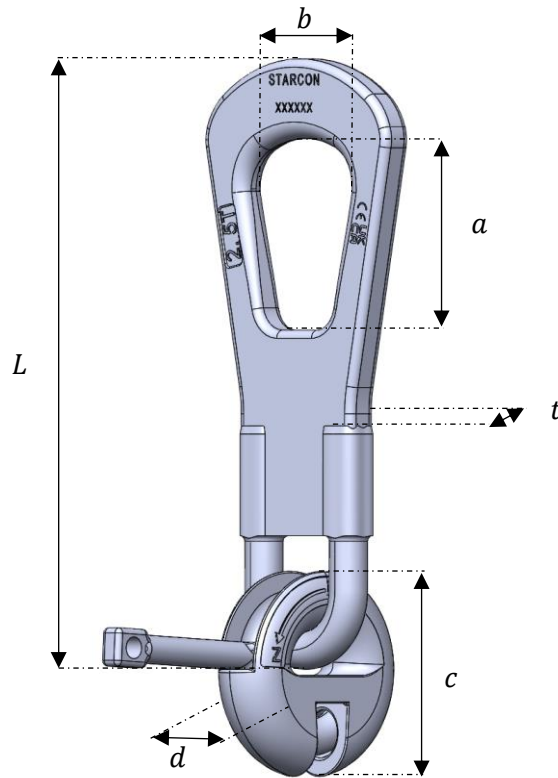

Figure 12 Ring clutch sketch.

### 16.1 Technical data

Table 11 shows the dimensions of the various types of ring clutch.

Load group	Length plate. L mm	Length hole a mm	Width hole b mm	Clutch head diameter c mm	Head thickness. d mm	Thickness of the plate t mm
2.5S	265	70	58	80	27	12
5.0S	330	86	65	105	36	16
10S	425	112	90	150	50	25
26S	605	160	120	206	72	30

Table 12 Ring clutch dimension.

## 17 Product data of ring clutch with wire

Figure 11 shows a measurement sketch for the ring clutch with wire.

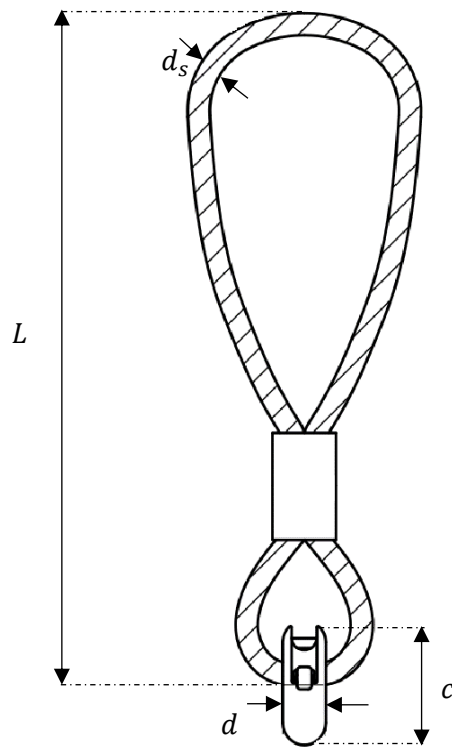

Figure 13 Ring clutch sketch.

### 17.1 Technical data

Table 13 shows the dimensions of the various types of ring clutch with wire.

Load group	Wire length. L mm	Clutch head diameter c mm	Clutch head thickness. d mm	Thickness of the plate d <sub>s</sub> mm
1.3S	330	50	18	8
2.5S	540	80	27	14
5.0S	615	105	36	16
10S	715	150	50	24

Table 13 Ring clutch with wire dimension.

## 18 Product data of former for STA.

Figure 14 shows a measurement sketch for the former.

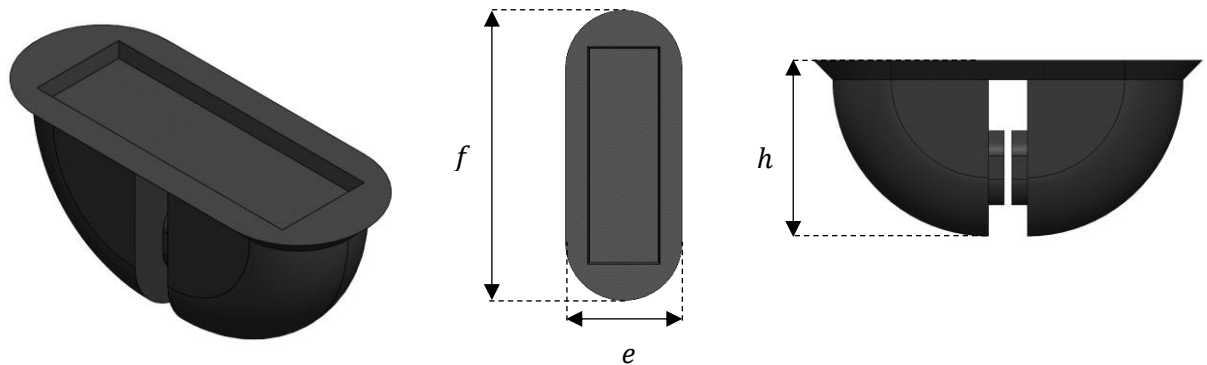

Figure 14 Former for STA.

### 18.1 Technical data

Table 14 shows the dimensions of the various types of the former used for casting of the STA F.

Former STA Load class	e mm	f mm	h mm	Thread M
2.5S	43	104	45	8
5.0S	49	126	59	8
10S	67	188	85	12
26S	112	234	118	16

Table 14 Dimension of former for STA former.

## 19 EC – Declaration of Conformity of the Machinery

This certificate meets the requirements of the Directive 2006/42/EC Annex II.

Manufacturer and responsible for compiling the technical documentation:

Company:	<b>CERTEX Danmark A/S</b>	Tel. No.:	<b>+45 74 54 14 37</b>
Address:	<b>Trekanten 6-8 6500 Vojens Denmark</b>	E-mail:	<b>info@certex.dk</b>

The undersigned hereby declares that the below specified tool comply with the current safety and health rules and legislation within the European Union. If any changes are made on the tool without approval from the manufacturer, this Declaration no longer applies.

<b>Description:</b>	<b>STA F</b>
<b>Drawing No.:</b>	<b>65011XXXXXXXXXX</b>
<b>Serial No.:</b>	<b>XXXXXX</b>
<b>Lifting Capacity:</b>	<b>WLL pr unit</b>
<b>Own Weight:</b>	<b>Kg pr unit</b>

Is made in accordance with the following EC-directive;  
**2006/42/EC**

The following standards have been used:  
**EN 13155+A2 : 2009**

Date:

---

For CERTEX Danmark A/S

## Our industries, products & services

At CERTEX Denmark, we are a secure and reliable total supplier and partner within lifting equipment. Below is an overview of the industries we service, our product range, and the services we offer."

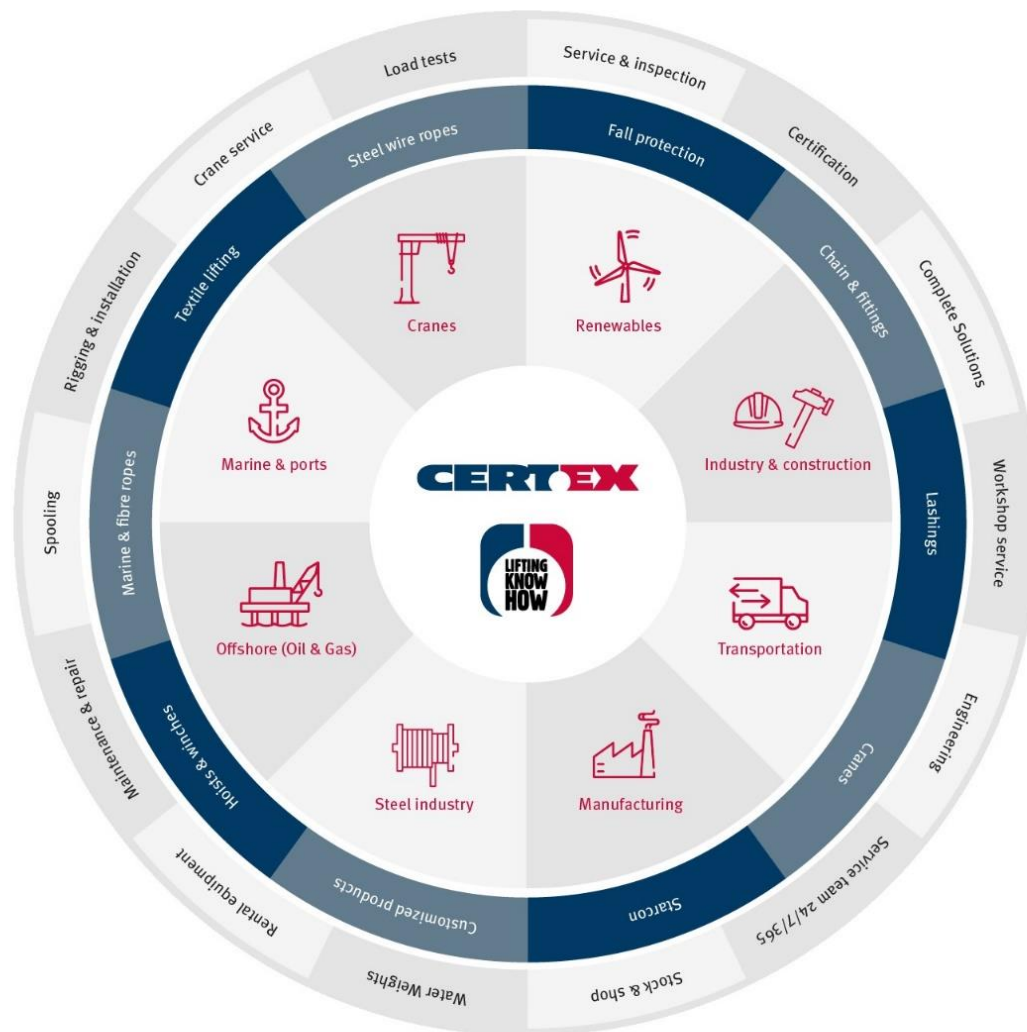



"

**Based on many years of experience  
& know-how within lifting, load  
tests & engineering, CERTEX  
Denmark is your reliable partner &  
supplier of steel wire, lifting  
applications & related services."**