

STARCON

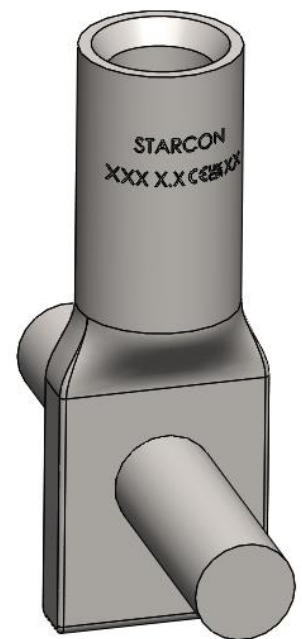

STARCON



Transport anchor with cross pin system 0.5S to 2.5S

User and design manual

Fixing insert systems for concrete elements.

1 Nomenclature

Symbol	Description	Unit
$^{\circ}C$	Temperature Celsius	$^{\circ}C$
B	Minimum plate thickness of a tile/slap/deck	mm
COG	Center of gravity	[-]
D	Diameter of the transport anchor	mm
\emptyset	Diameter of the cross pin	mm
d_{s1}	Diameter of the rebar	mm
N	Axial load	N
V	Shear load	N
L	Length of the transport anchor	mm
L_1	Length of the corss pin	mm
$L_{b,net out}$	Length of the rebar	mm
h_{ef}	The anchorage depth	mm
C_1, C_2, C_3, C_4	Edge distances	mm
S	Load group symbol (STARCON)	-
S_z	Distance between Transport anchors	mm
WLL	Working Load limit	tons

Table 1 Nomenclature

Starcon Precast Concrete Design & Fixing insert Manual

1	Nomenclature	1
2	Identification.....	2
3	Introduction Starcon transport anchor with cross pin system 0.5S to 2.5S	3
4	Safety instructions before use	4
5	Advantages of the Starcon system.	4
6	Using the Starcon system.....	5
7	Safety factors for lifting systems:	6
8	General information	7
9	Design method.....	8
10	Recommend casting/placement of the anchor in concrete elements.	11
11	Starcon Transport anchor with cross pin load data.....	13
12	General safety information when using the Starcon system.	14
13	Maintenance and inspection	16
14	Disposal / Recycling	17
15	Product data of transport anchors with cross pin	17
16	Product data of connection holding plate for transport anchors.....	18
17	Product data of Lifting loop	19
18	Product data of Alpha inclined pull lifting loop	20
19	Product data of Goliath lifting loop	21
20	EC – Declaration of Conformity of the Machinery.....	22

2 Identification

Table 2 provides insight into the revision number of this document. It facilitates tracking changes and ensuring version control for accurate referencing and updates.

Version	Responsible	Creator	Date	Comment
A	CERTEX Denmark	JLJ	08-08-2024	New documentation

Table 2 Revision table

3 Introduction Starcon transport anchor with cross pin system 0.5S to 2.5S

Read this instruction manual before using the transport anchor with cross pin.

Incorrect use can cause injury or danger!

Safety is paramount when using fixing devices and equipment. Only trained individuals should operate them as per national law. Familiarize yourself with the instruction manual before use to ensure safe operation. Adhering to these guidelines reduces the risk of accidents. Consult relevant national regulations as they may supersede these instructions. All individuals involved with the equipment must read and understand this manual. Contact Certex for assistance or clarification. Always keep the manual with the product. Contact information is provided on the last page.



General concept of the use transport anchor with cross pin:

The Starcon Fixing insert system consists of two key components: Starcon transport anchor with cross pin and Starcon Connection holding plate shown on Figure 1

To ensure proper placement of the fixing socket unit in the finished concrete product, the head of the Starcon insert for fastening with angle is assembled into a corresponding Starcon nailing plate before pouring. Once the concrete reaches a strength of at least 15 MPa, connection holding plate can be removed. At the installation site, connecting and securing precast concrete components may only commence when the concrete has reached a strength of at least 25 MPa. Contact CERTEX DK for lower strength values.

The Starcon transport anchors and systems use the guidelines described in the German guidelines VDI/BV-BS 6205 and Technical Report CEN/TR 15728, based on CEN TS 1992-4 and combined with EN 13155-2009. This ensures the highest level of safety when using our products.

Material: Steel.
Surface treatment: White zinc plated (WZP).

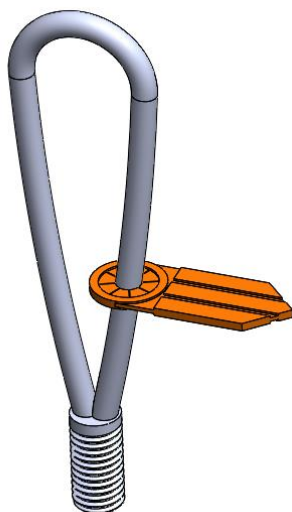

Lifting loop

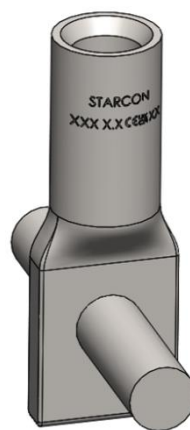

Transport anchor with cross pin

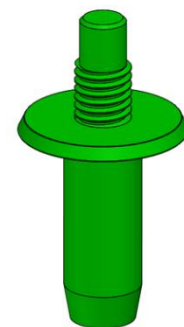

Connection holding plate

Figure 1 Starcon lifting system.

4 Safety instructions before use



- The Starcon transport anchor with cross holes must only be installed on a Starcon nailing plate of the same rating.
- Starcon transport anchors with cross holes that are exposed to corrosion, or damaged must not be used.
- The Starcon transport anchor with cross holes must only be hoisted by a lifting loop of the same size.
- The Starcon lifting and handling system must not be used to lift more than the specified load.
- The Starcon lifting and handling system must not be used for personnel lifting.
- The Starcon products are designed for one-time lifting only.
- The Starcon lifting system must only be used by skilled, trained employees.
- A lifting accessory used with the lifting loop must be correctly marked and approved for lifting.
- Before use, check the weather conditions. Never operate the system if there is a likelihood of lightning in the area and avoid use in extreme weather conditions such as storms, heavy rain, or snowing.
- The concrete safety factor assumes a factory production control complying with EN13369. If these requirements are not fulfilled, a safety factor of $\gamma = 2,5$ shall be used.
- All relevant concrete failure modes shall be verified by the pre casting manufacturer of the concrete elements; the different failure modes and verification methods are specified in EN13155 (Annex H).

5 Advantages of the Starcon system.

The Starcon system offers transport anchors with cross pin. These specialized fasteners are an effective solution for connecting and securing precast concrete components on site. The system comprises fixing sockets pre-set in the concrete, along with other connecting elements and accessories.

The Starcon system is available in load groups 0.5S to 2.5S. It is typically embedded in the concrete element during the prefabrication stage. When connection is needed, we will screw or bolt into the anchor socket. The applied force is transmitted evenly into the concrete through the anchor socket.

The system's efficiency has been proven through many years of successful use. Components are regularly tested during production and are clearly marked with the maximum load. The transport anchors with cross pins are individually tested and come with a traceability batch code.

5.1 Note

The information in this manual is for guidance only, and the use of the manual does not in any way exempt the manufacturer from ensuring that the chosen fixing system is suitable for the intended purpose. The information and data listed in this manual only refer to original Starcon products supplied by *CERTEX DANMARK A/S*.

6 Using the Starcon system

The Starcon system comprises a wide range of anchors in a load group from 0.5S to 2.5S per anchor with various lengths. The principle for using the system is the same for the entire range. The Starcon system consists of the following two main components:

6.1 Starcon Transport anchor with cross pin

The Starcon transport anchor is a steel embedded member with a specially designed foot for secure anchoring in hardened concrete. The Starcon transport anchor with cross pin is a cylindrical, internally threaded unit, connects to other components using screws or bolts. Starcon transport anchors are clearly labelled with dimensions (e.g. 0.5S) and are available in a variety of lengths. They undergo specimen testing for defects, dimensional deviation and tensile strength with a minimum safety factor of 3:1 against metal failure.

6.2 Starcon Connection holding plate

The connection holding plate, typically made of cylindrical plastic components with a threaded end, must be carefully attached to the anchor head and positioned correctly before being securely fastened to the formwork. After the concrete cures and hardens, the connection holding plate is removed, exposing the anchor head seated in a trapezoidal depression. Since the connection holding plate is typically stripped and unscrewed during removal, it's not normally reusable.

6.3 Starcon Lifting Loop

Starcon lifting loops are devices used to attach cables or slings to objects for lifting. Typically made of forged steel, they come in various shapes and sizes to suit different lifting capacities and applications. Starcon lifting loops undergo rigorous testing to ensure their safety. Each loop is marked with its article number, identification number, and maximum working load, along with a clear indication of a 4:1 safety factor. Additionally, a certificate is issued with every delivery for complete documentation.

An additional safety measure is that the Starcon system is available in several non-compatible load groups. It is not possible to incorrectly assemble components from different load groups, thus avoiding failure of the lifting arrangement.

6.4 Lifting loop assembly instructions.

Screw the lifting loop by hand into the threaded hole of the transport anchor. Ensure the threads engage fully and easily without any cross-threading. If necessary for proper sling alignment during lifting, you may loosen the connection by one turn of the lifting loop. The system allows safe lifting in a vertical direction and up to a maximum tilt angle of 45 degrees in all directions. The instruction is shown and explained in Table 3

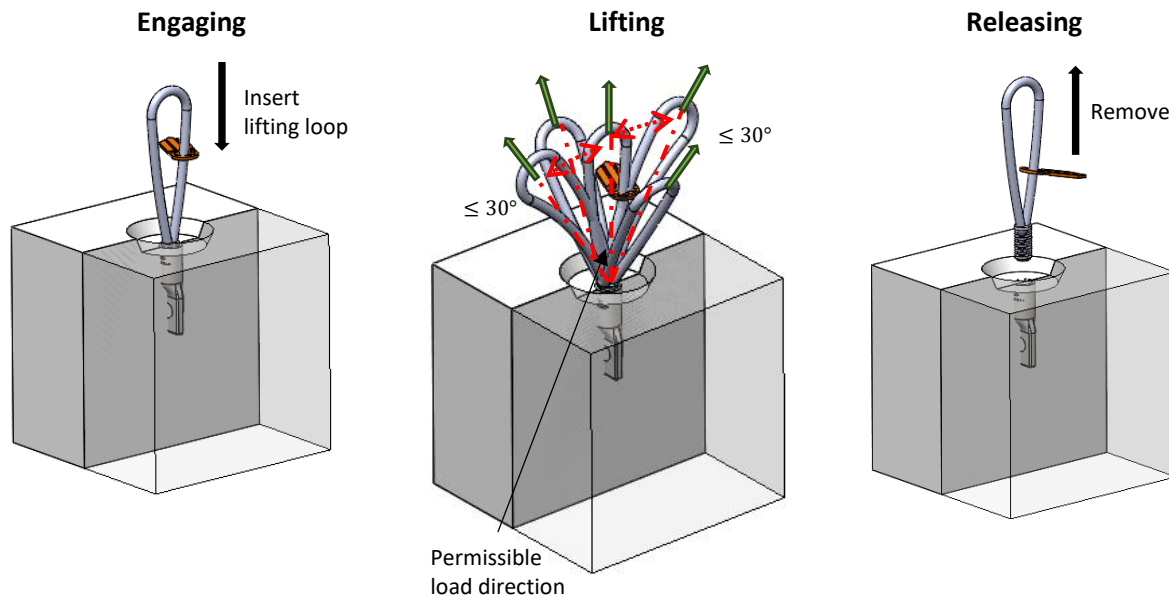

Verify that the transport anchor load capacity matches the lifting loop.
 Manually insert the lifting loop into the transport anchor.
 Once hand-tight, visually check that the lifting loop sits flush against the transport anchor.
 You can begin the lifting process.

Lifting loops are designed to handle loads in vertical and tilted orientations, provided the load limits of the transport anchors are not exceeded. The tilt lift should normally not exceed 30 degrees in all directions. When using a spreader beam, the tilt angle of the load can be reduced.

Manually disconnect the lifting loop by turning it out of the transport anchor.

Table 3 The connection between the lifting loop and transport anchor.

7 Safety factors for lifting systems:

For the calculations of the lifting system, the following safety factors shown Table 4 have been applied to ensure its reliability and safety. These factors, in accordance with the recommendation of EN13155, have been carefully selected as guidelines to ensure optimal safety during the system's operation.

Failure safety factors	
Steel failure of anchors	$SF_{Steel} = 3$
Concrete pull out failure	$SF_{concrete} = 2,5$
Failure in the lifting loop	$SF_{Link} = 4$

Table 4 Failure safety factors

8 General information

This section provides essential details on the Starcon transport anchor systems, offering clarity and guidance for safe and efficient usage.

8.1 Marking on the transport anchor with cross pin

Each transport anchor is clearly labeled with its load capacity, thread size, and manufacturer's identification, ensuring easy and secure identification of the systems, even post-installation show on Figure 2.

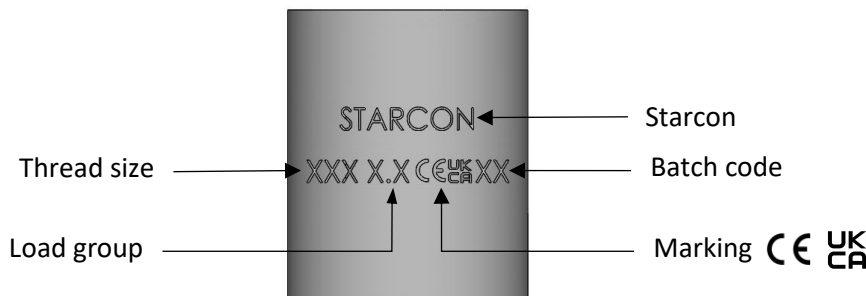

Figure 2 Marking on the cylinder of the transport anchor with cross pin.

8.2 Guidelines for Transport anchor selection

When selecting transport anchors with cross pins, it's essential to consider various factors to ensure safety and effectiveness. The tables provided contain crucial information such as maximum load capacities, edge distances, and installation values for different transport anchor types. Key points to consider:

- Weight of the precast element.
- The number of transport anchors with cross hole.
- How the anchors are arranged.
- The load-bearing capacity of the transport anchors with cross hole.
- Compressive strength of concrete.
- Concrete quality.
- Environmental impact on the use.

8.3 Guidelines for installation

For the Starcon transport anchor systems to be appropriately installed, it is imperative to ensure compliance with specific technical criteria and prerequisites:

- Adherence to load capacity specifications of the anchor.
- Maintaining appropriate edge spacing.
- Ensuring the concrete grade is suitable.
- Verifying alignment with the load direction.
- Additional reinforcement requirements.

8.4 Guideline for load capacity

Load capacity of an anchor relies on several factors:

- The length of the anchor.
- The spacing between the anchor and the edges, both axially and along the edge.
- The direction of the applied load.
- The arrangement of reinforcement within the concrete structure.

9 Design method

This section provides essential information for the correct and safe selection and use of anchor sockets. To ensure the construction's durability and safety, it is crucial to carefully follow the manufacturer's technical specifications and guidelines during design and construction. Additionally, the casting process is discussed, including the transfer of load to the concrete using the anchor base, and the importance of correctly placing formwork and anchors during casting to avoid errors and risks. Warnings are given regarding the correct size of formwork and the risk of errors with incorrect sizes, which can lead to potentially dangerous situations.

9.1 Load Transfer with Anchor Casting

Load transfer to the concrete is made easier by the cross pin, which means it can handle heavy loads even with short anchors shown on Figure 3. However, with very thin elements, these concentrated loads can cause lateral spalling because of the strong pulling forces. The concrete must withstand a minimum resistance of 2.5 units before experiencing structural failure.

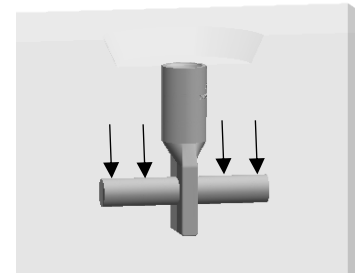

Figure 3 Load transfer.

9.1.1 Correct placement of nailing and transport anchors during casting.

Caution: If the connection holding plate is too small, it won't be compatible with the fixing equipment later. Conversely, if the recess block is too large, attaching the fixing equipment correctly will be impossible, increasing the risk of the fixing equipment slipping out. This could lead to premature transport anchor failure and the subsequent collapse of the construction element. Always ensure the connection holding plate size matches the identified appropriate size. Figure 4 illustrates the correct placement of the connection holding plate in wet concrete to ensure optimal anchorage strength for the transport anchor.

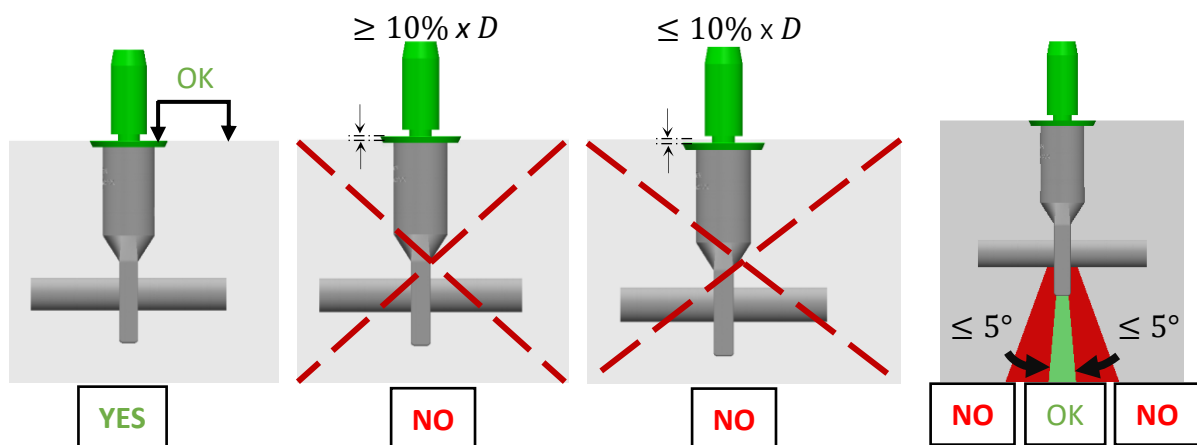

Figure 4 Correct placement of connection holding plate.

9.2 Calculate load cases of removing from formwork and transport.

To ensure proper anchoring, each anchor must consider several factors: weight of the element, adhesion to the mold, shock load, sling angle, and the number and position of the anchors.

When lifting a concrete unit from a form, consider the adhesion factor between the concrete and the mold. For complex shapes, adhesion can increase anchor load, especially when concrete strength is at its lowest. Calculate the total weight of the elements in tons, including all equipment and accessories attached to the device.

9.2.1 Load case removing the formwork and transport of the element.

The tension force F_A in each the anchor:

1. Load case when removing the element from the formwork:
$$F_A = \frac{(F_Z + S * Pa) * F_S}{n}$$

2. Load Case during transport lifting of the element.
$$F_A = \frac{F_Z * F_S * \varphi_{dyn}}{n}$$

Where,

- F_Z : Weight of the concrete element in Tons (*tonne*)
- S : Surface area of the mould in contact with the fresh concrete (m^2)
- Pa : Adhesion factor between the pouring box and concrete (See Table 6)
- F_S : Sling angle factor (See Table 5)
- n : Number of load-bearing anchors in the element.
- φ_{dyn} : Dynamic factor of the element under transport

9.2.2 Sling angle factor (F_S)

The illustration in Figure 5 provides a visual explanation of how to measure the sling angle. Referencing Table 5, you can find the sling factor corresponding to the measured angle.

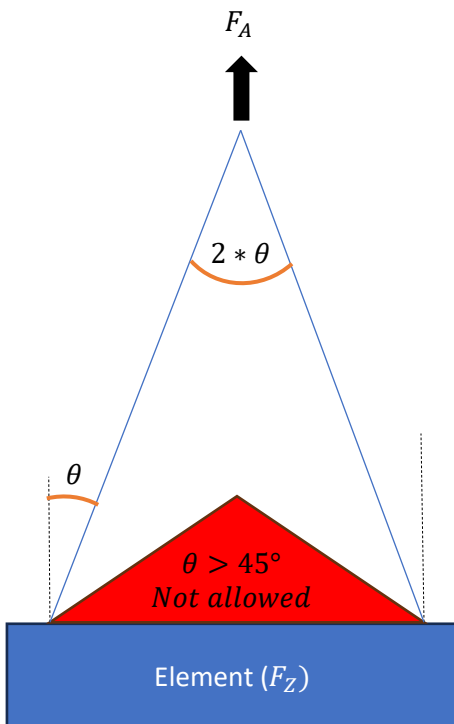

Figure 5 Sling angle factor illustration.

Sling angle degree (θ)	Sling factor (F_S)
0°	1
10°	1,02
20°	1,07
30°	1,16
45°	1,41

Table 5 Sling angle factor

9.2.3 Adhesion to formwork factors (Pa)

Adhesion factor between the pouring box and concrete is shown in Table 6.

Mould type	Adhesion ($\frac{\text{tonnes}}{m^2}$)
Lubricated steel form work	$Pa = 0,1$
Varnished timber formwork	$Pa = 0,2$
Rough formwork	$Pa = 0,3$

Table 6 Adhesion factor to formwork

9.2.4 Dynamic factors (φ_{dyn})

If the concrete unit is handled or transported by mechanical equipment, it is exposed to shock/impact from gripping and transport over uneven ground. This factor can increase the anchor load several times its own weight. The correct load can be determined by adding the dynamic factor φ_{dyn} shown in Table 7

Lifting condition	Dynamic load factor
Static crane, rope speed <90 m/min	1
Static crane, rope speed >90 m/min	1,3
Lift and transport with mobile crane on smooth ground	1,75
Lift and transport with mobile crane on uneven ground	2
Transport with forklift or excavator over uneven ground	3

Table 7 Dynamic factor

9.2.5 The number and position of lifting points

The effective load carried by each anchor is typically calculated by dividing the total weight by the number of load-bearing anchors. However, this calculation assumes equal load distribution among all anchors. If the load distribution is unequal, the load to be carried by each anchor should be determined using static calculations as shown in Figure 6.

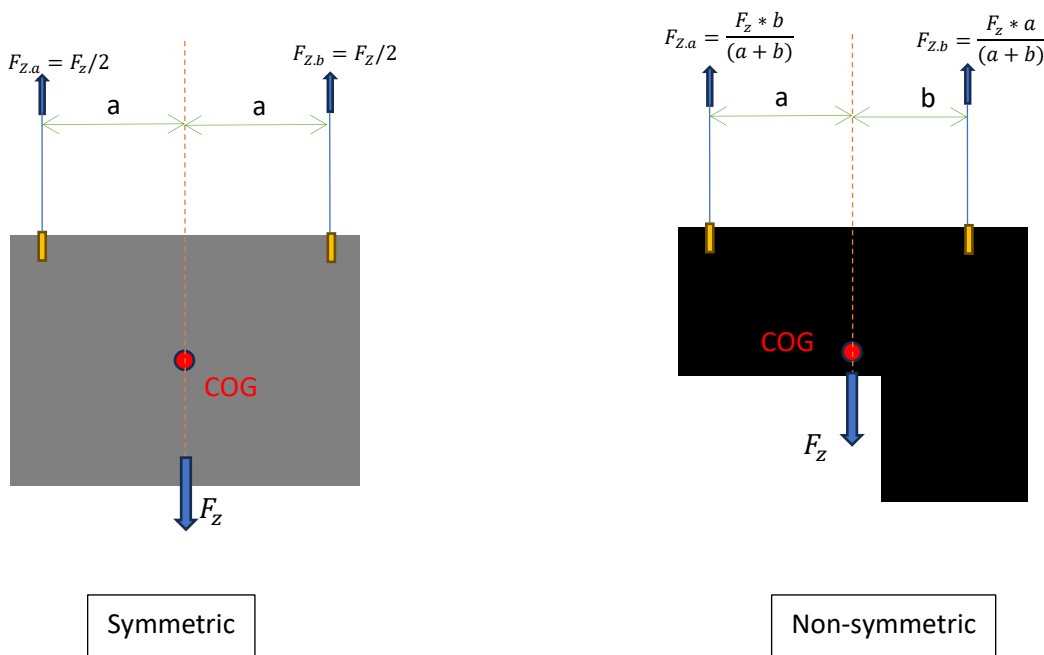

Figure 6 Calculation symmetric and non-symmetric loading element.

10 Recommend casting/placement of the anchor in concrete elements.

Figure 7 shows a measurement sketch for the Recommend casting/placement of the anchor in concrete elements. The minimum edge distances required for the anchor to ensure adequate load distribution and to prevent edge failures.

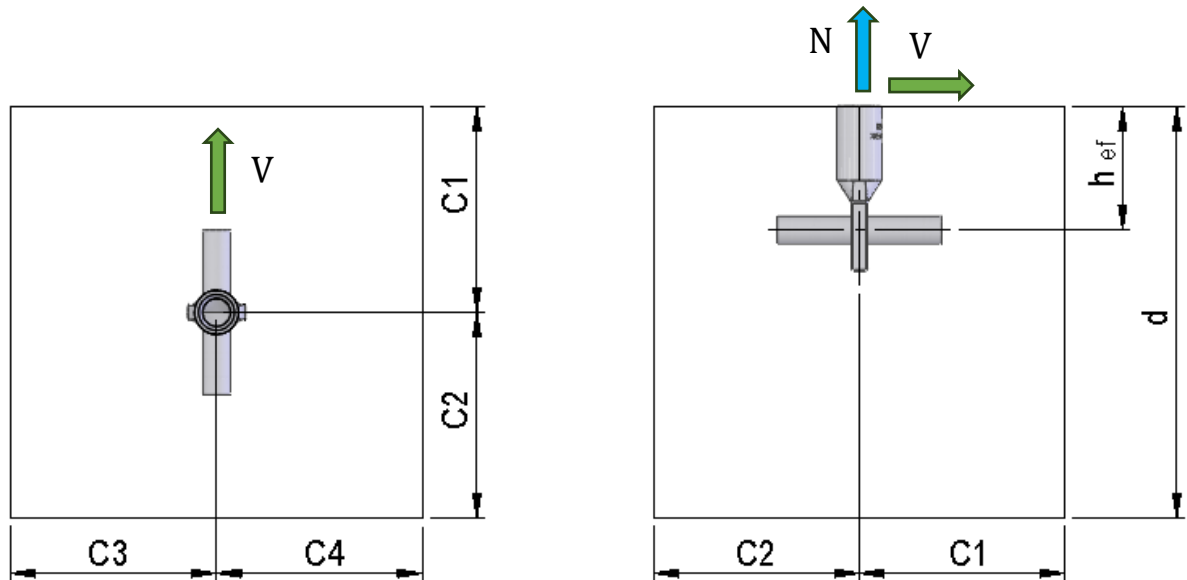

Figure 7 Casting/placement of the anchor in concrete elements.

Table 8 shows the dimensions of the various types of concrete part.

Type	Close to the edge		Away from the edge		Anchor depth	Min. depth of concrete
	C_1, C_3, C_4 mm	C_2 mm	C_1, C_3, C_4 mm	C_2 mm	① h_{ef} mm	d mm
M12x60	80	500	160	500	50	90
M16x79	100	500	200	500	67	120
M16x100	130	500	260	500	91	140
M20x99	130	500	250	500	84	130
M20x120	160	500	320	500	105	130
M24x115	150	500	300	500	98	150

C_1 : Edge distance to the point of shear load application on the free edge.

C_2 : Edge distance in the direction opposite to the applied load.

C_3, C_4 : Distances from the edge that are perpendicular to the direction of the shear load.

Min. spacing of $2 \times C_3$ must be maintained between two or more sockets

① h_{ef} = increase of the anchorage depth because of the influence of the cross pin.

$$h_{ef} = h_{ef1} + 1/2 * \Delta h_{ef} \text{ with } \Delta h_{ef} = 0.5 \times L_1 / \tan 57^\circ$$

Ensure that the transport anchor with cross pin is oriented with the pin parallel to the direction of the shear force as illustrated here.

Table 8 Dimension of the Concrete part

10.1 Reinforcement

This section details the specifications for reinforcement when using fastenings in concrete.

- Close reinforcement ($e < 150$ mm with B500B $d_s \geq 12$ mm or $e < 100$ mm with B500B $d_s \leq 10$ mm).
- Reinforcement/ U bar at the edge of the concrete part.
- Insert in cracked concrete and in pressure zone.
- Shear supplementary rebar.

Figure 8 shows a measurement sketch for the shear supplementary rebar

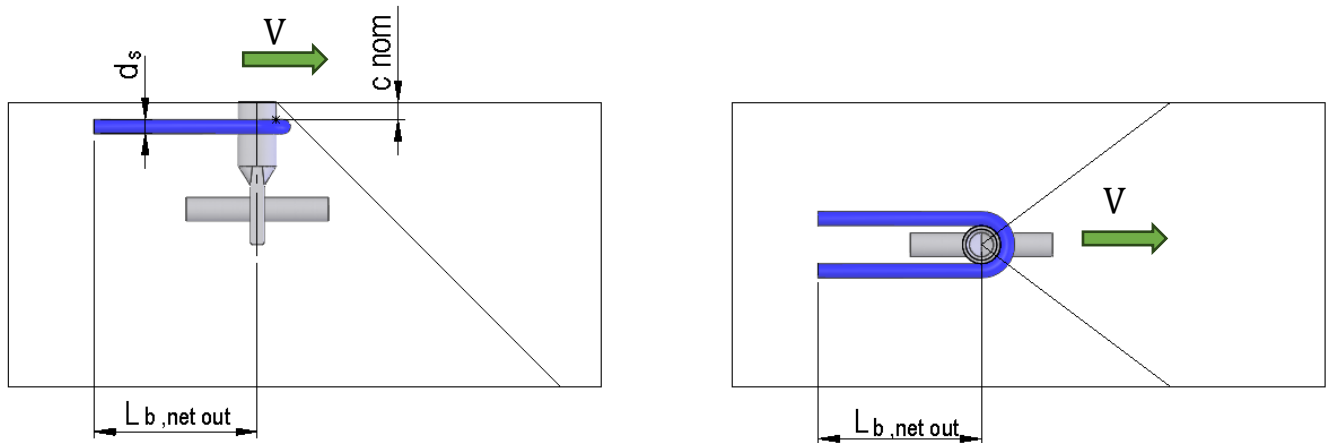

Figure 8 Shear supplementary rebar

Table 9 shows the dimensions of the various types of shear supplementary rebar.

Type	Shear supplementary rebar	
	Diameter of rebar	Length of the rebar
	d_s mm	$L_{b,net out}$ mm
M12x60	6	100
M16x79	8	150
M16x100	8	200
M20x99	10	200
M20x120	10	200
M24x115	12	200

C_{nom} : denotes the nominal cover, which is the distance from the surface of the concrete to the nearest surface of the embedded reinforcement. A proper cover is essential to protect the reinforcement from corrosion and ensure the overall durability of the structure.

Table 9 Dimension of shear supplementary rebar.

11 Starcon Transport anchor with cross pin load data

Table 10 provides information to assist in determining appropriate cross pin sockets under conditions with varying axial and shear load design on the sockets, conducted in unreinforced C20/25 and C30/37 concrete, and shear load with shear supplementary rebar.

The static calculation of the transport anchor with a cross pin is performed according to CEN TS 1992-4:2009 - Design of fastenings for use in concrete.

The following boundary conditions are utilized for the calculation:

- **1 anchor** symmetrically positioned to the center of gravity.
- **Dynamic factor** (site handling) $\Gamma_{dyn} = 1.3$

Load group	Type	Edge		Concrete strength	Design load [Ton]					
		Close	Away		Cracked zone			Pressure zone		
					Axial N_{RD}	Shear V_{RD}	Shear + rebar $V_{RD, re}$	Axial N_{RD}	Shear V_{RD}	Shear + rebar $V_{RD, re}$
0.5S	M12x60	x		C20/25	0,57	0,43	0,57	0,8	0,61	0,68
		x		C30/37	0,69	0,53	0,69	0,97	0,75	0,89
			x	C20/25	0,57	0,57	0,57	0,8	0,8	0,8
			x	C30/37	0,69	0,69	0,69	0,97	0,97	0,97
1.2S	M16x79	x		C20/25	0,93	0,64	1,36	1,3	0,9	1,36
		x		C30/37	1,13	1,49	1,72	1,59	1,84	1,84
			x	C20/25	0,93	1,23	1,36	1,3	1,73	1,73
			x	C30/37	1,13	1,49	1,72	1,59	1,84	1,84
	M16x100	x		C20/25	1,58	0,95	1,72	1,84	1,34	1,72
		x		C30/37	1,84	1,16	1,72	1,84	1,64	1,72
			x	C20/25	1,59	1,73	1,73	1,84	1,84	1,84
			x	C30/37	1,84	1,84	1,84	1,84	1,84	1,84
2S	M20x99	x		C20/25	1,49	0,99	2,27	2,09	1,4	2,27
		x		C30/37	1,81	1,2	2,68	2,5	1,7	2,68
			x	C20/25	1,49	1,66	2,27	2,09	2,35	2,35
			x	C30/37	1,81	2,03	2,68	2,5	2,86	2,86
	M20x120	x		C20/25	2,26	1,31	2,27	2,5	1,85	2,27
		x		C30/37	2,5	1,59	2,68	2,5	2,25	2,68
			x	C20/25	2,26	2,28	2,28	2,5	2,88	2,88
			x	C30/37	2,5	2,77	2,77	2,5	2,88	2,88
2.5S	M24x115	x		C20/25	2,09	1,26	2,72	2,5	1,78	2,72
		x		C30/37	2,5	1,54	3,55	2,5	2,88	2,88
			x	C20/25	2,1	2,18	2,72	2,5	3,08	3,08
			x	C30/37	2,5	2,65	3,55	2,5	3,74	3,74

Interaction – axial load and shear load at the same time: (Utilization axial direction) + (Utilization in shearing) $\leq 120\%$

$$N_{SD} / N_{RD} + V_{SD} / V_{RD} \leq 1,2$$

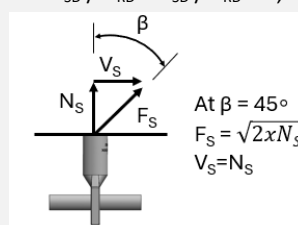

Close: to the edge.

Away: from the edge.

Disclaimer: The table serves solely as a guideline. For accurate guidance and calculations, please contact www.Certex.dk.

Table 10 Transport anchor with cross pin load data.

12 General safety information when using the Starcon system.

General safety information when using the Starcon system.



- Ensure that the marking on the Starcon lifting unit always points in the direction of pull during lifting.
- The lifting machine must be approved to lift at least the maximum applied load + the weight of the Starcon lifting and handling system + any hoisting accessories.
- Lifting movements must be smooth; no sudden or abrupt changes in direction with the lifting machine should be made during a lifting operation, as this can lead to pendulum movements of the load, causing crushing hazards or dropping of the load.
- Where there is a risk of crushing between the load and objects, building parts, machinery, etc., the operator must not be in the danger zone.
- The operator's work area must be flat and free of obstacles that could pose a tripping hazard.
- When depositing the load, the operator must ensure this accepts on a flat and stable surface.
- Only when the load has been deposited and secured the Starcon lifting unit is completely unloaded may it be released and lifted free.
- Before each lift, ensure that both the Starcon lifting unit and the Starcon lifting anchor embedded in the concrete product are free from dirt that could reduce grip.
- Never insert arms or feet under a concrete product.
- Concrete products must never be dragged, only lifted.
- No modifications to the Starcon lifting and handling system may be made without written permission from the manufacturer.
- The operator must always ensure that the connection between the lifting machine and/or any hoisting accessories and the Starcon lifting unit is correct and secured against unintentional detachment.
- The operator must always ensure that the connection between the Starcon lifting unit and the Starcon lifting anchor is correct and secured against unintentional detachment.
- Keep a safe distance and never walk under a suspended load.
- Use gloves, safety shoes and other PPE when handling.
- Never use a Starcon lifting and handling system that has visible defects such as wear, deformations, rust damage, etc.
- Most anchors are designed to be easily handled during installation without the need for lifting equipment. However, some anchors may weigh more and should be handled using lifting equipment. Please refer to the order list for the accurate weight of each product.

12.1 Personal Protection

Always use gloves, a safety helmet, and safety shoes as a minimum requirement when operating the equipment. Keep hands and other body parts away from the lifting stand, lifting accessories, and the load during use.



12.2 Preparation of the product before use

12.2.1 Transport and Storage

Anchors should be transported and stored safely to prevent risks to personnel and nearby objects.

12.2.2 Unpacking

Remove the pallet and packaging protecting the anchors.

Cut the safety straps. The person unpacking should wear gloves, safety shoes, and safety glasses when cutting the straps.

12.2.3 Safe Disposal of Packaging Materials

All packaging used by Certex Denmark can be reused. Pallets and all wooden packaging can be reused or recycled.

All plastic, cardboard, and paper materials should be sent to the local recycling center.

If there are no local recycling facilities, the packaging should be returned to Certex Denmark for disposal at the customer's expense.

12.2.4 Preparatory Work Before Installation

After unpacking, visually inspect the anchors for any damage.

12.2.5 Installation and Assembly

The anchors are delivered ready for use.

12.2.6 Storage and Protection Between Periods of Normal Use

Inspect the anchors before each use and lift. Never use anchors or lifting accessories with visible defects such as wear, deformations, corrosion damage, etc.

Always store the lifting bar indoors, in a dry and ventilated area.

12.2.7 Provision of Information (Users, Operators, Service Experts)

All operators or individuals within the danger zone must receive information on operating the anchors and must be trained by the supervisor, familiarizing themselves with the product and its use before lifting operations commence.

Operators must be trained in the use of the lifting bar and all its functions and positioned to have a clear view of the entire lifting operation.

12.2.8 Placement of Instruction

All user manuals should always be stored together with the lifting bar.

13 Maintenance and inspection

- All maintenance must be performed when the Starcon lifting unit is unloaded.
- The Starcon lifting unit should be inspected and maintained to ensure it remains in proper condition during use.
- After each use, the Starcon lifting unit should be cleaned and inspected for any faults or deficiencies.
- If any faults are found, they must be rectified, or the Starcon lifting unit should be discarded.
- The Starcon lifting unit should always be stored in a dry and well-ventilated area.
- Any damaged, corroded, or worn-out Starcon lifting unit must be immediately taken out of service and marked not be used again.
- Equipment from Starcon should undergo at least one annual inspection by a qualified skilled person to inspect lifting equipment and cranes.

13.1 Maintenance Schedule



- Only original spare parts may be used, and they must be replaced by a trained individual.
- The annual inspection must be carried out by a qualified individual who has received the necessary training and certification for lifting equipment.
- All services must be documented, and the data must be stored.
- If there are any visual defects or if the labeling is not present on the lifting stand, the lifting stand must be marked as "out of service".

B Before use

A After use

M Monthly, or a maximum of 200 hours of usage.

Y Annually, or after a maximum of 2400 hours of use.

Inspection	B	A	M	Y
Perform a visual inspection to check for signs of overload, deformation, damage, wear, and corrosion.	X	X	X	X
The equipment must undergo inspection.			X	
Ensure that the equipment is ready and clearly labeled.			X	X
Inspection should be carried out by a qualified individual with a report prepared.				X

Table 11 Maintenance schedule

14 Disposal / Recycling

This section describes the end of use for the product.

- End of use / Disposal The lifting points shall be sorted / scrapped as general steel scrap.
- The Starcon lifting and handling system should be sorted and disposed of according to appropriate material categories, including metal, plastic, etc.
- Certex can assist you with disposal if required.

15 Product data of transport anchors with cross pin

Figure 9 shows a measurement sketch for the transport anchor with labels for the respective dimensions.

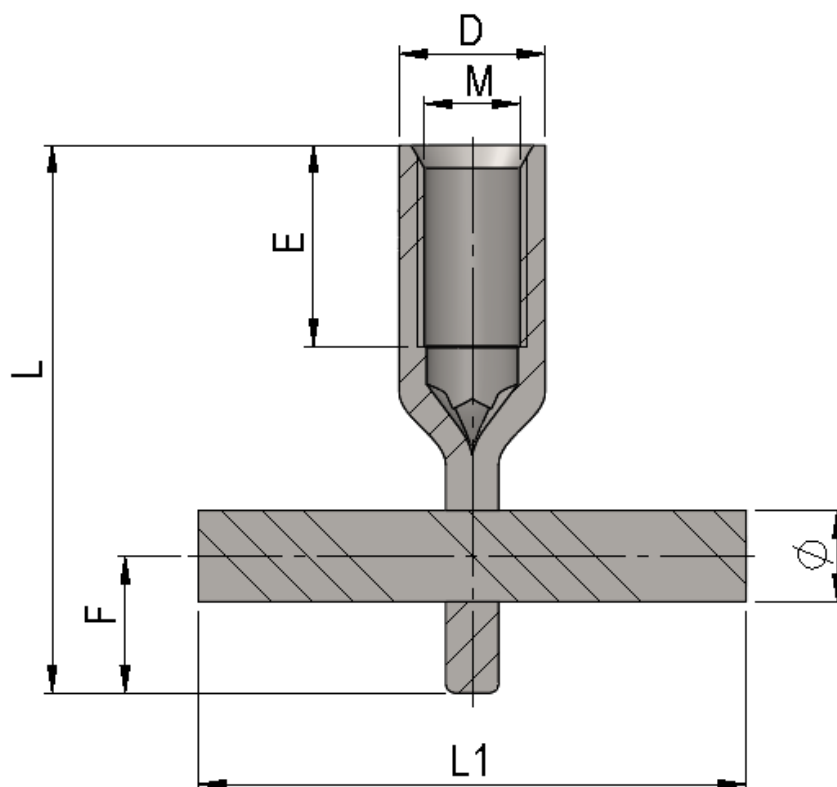

Figure 9 Transport anchor with cross pin sketch.

15.1 Technical data

Table 12 shows the dimensions of the various types of transport anchors with cross pin.

Load group	Anchor dia. D mm	Anchor length L mm	Dia. pin \varnothing mm	Pin length L_1 mm	Thread M mm	Thread length E mm	Pin distance F mm
0.5S	16	60	10	60	12	22	15
1.2S	21.5	79	12	80	16	25	19
	21.5	100	12	100	16	25	19
2S	27.5	99	14	100	20	30	24
	27.5	120	14	100	20	30	24
2.5S	31.5	115	14	100	24	32	26

Table 12 Transport anchor with cross pin dimension.

16 Product data of connection holding plate for transport anchors

Figure 10 shows a measurement sketch for the Connection holding plate.

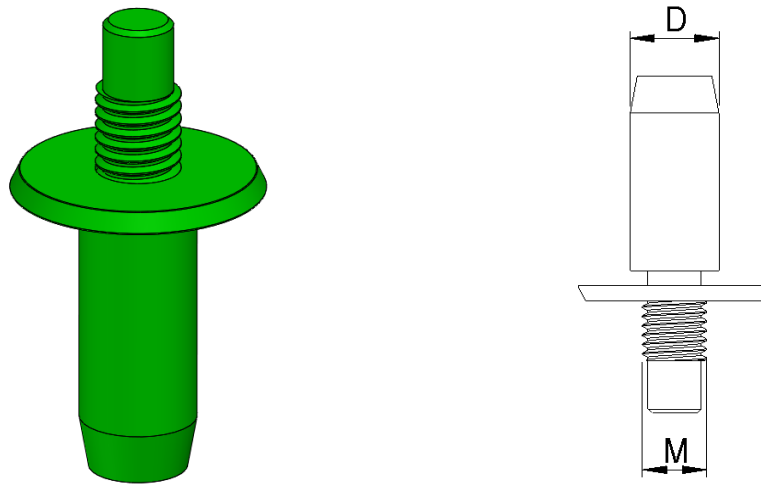

Figure 10 Connection holding plate for transport anchors.

16.1 Technical data

Table 13 shows the dimensions of the various types of the Connection holding plate used for casting of the transport anchors.

Connection holding plate Starcon Group	D mm
M8	11
M10	11
M12	11
M16	17

Table 13 Dimension of Connection holding plate for transport anchor.

17 Product data of Lifting loop

Figure 11 shows a measurement sketch for the lifting loop.

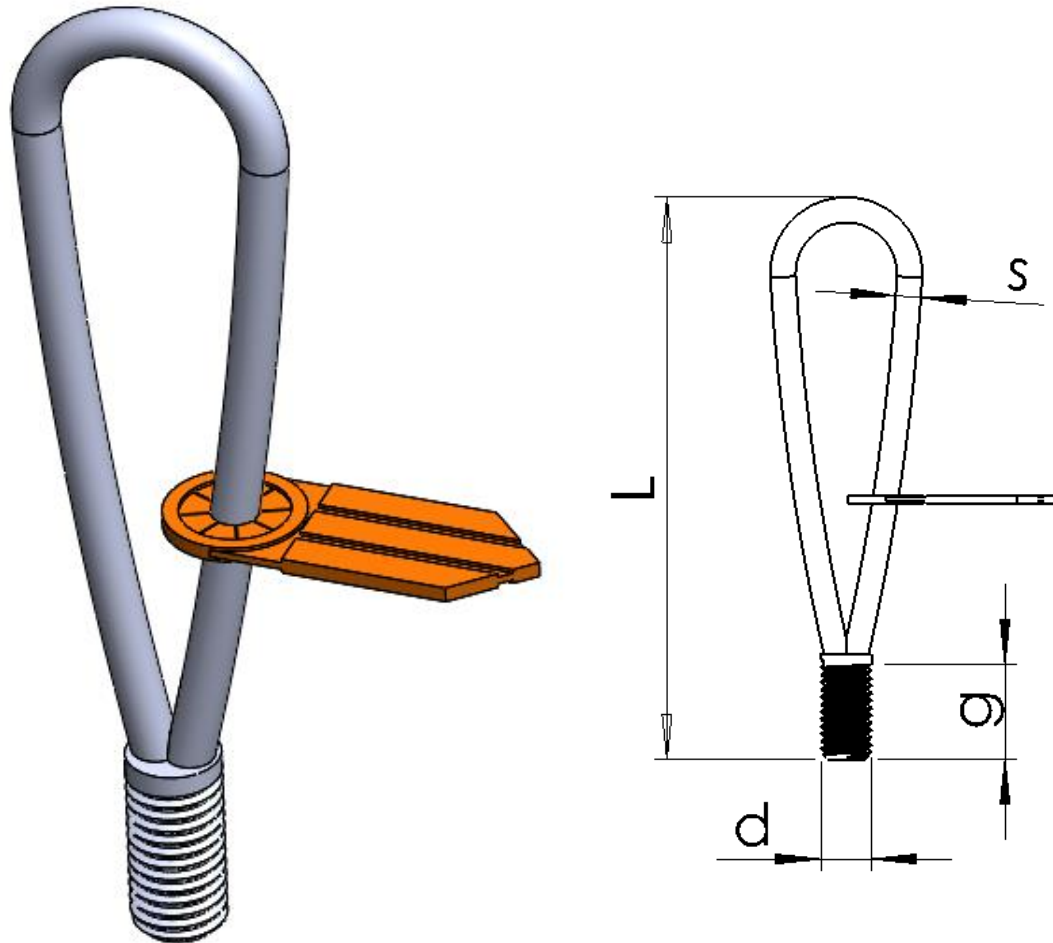

Figure 11 Lifting loop dimension sketch.

17.1 Technical data

Table 14 shows the dimensions of the various types of lifting loop.

Load group	Length of lifting loop L mm	Diameter of wire s mm	Thread d mm	Thread length g mm
0.5S	130	6	12	22
1.2S	170	8	16	27
2S	210	10	20	35
2.5S	260	12	24	43

Table 14 Lifting loop dimension.

18 Product data of Alpha inclined pull lifting loop

Figure 12 shows a measurement sketch for the pull lifting loop.

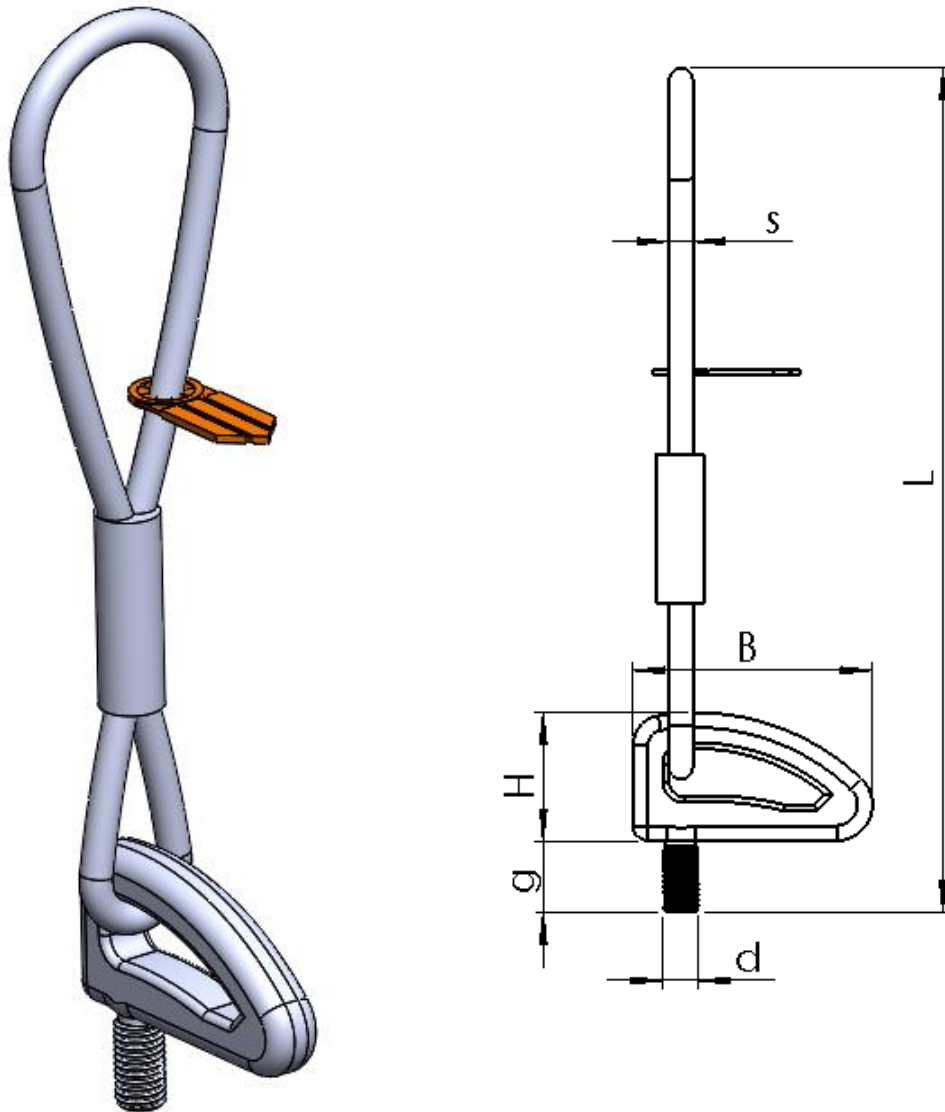

Figure 12 Pull lifting loop dimension sketch.

18.1 Technical data

Table 15 shows the dimensions of the various types of pull lifting loop.

Load group	Length of lifting loop <i>L</i> mm	Diameter of wire <i>s</i> mm	Ring width <i>B</i> mm	Ring height <i>H</i> mm	Thread <i>d</i> mm	Thread length <i>g</i> mm
0.5S	260	8	55	42	12	24
1.2S	320	10	55	42	16	28
2S	380	12	89	69	20	34
2.5S	430	14	89	69	24	39

Table 15 Pull lifting loop dimension.

19 Product data of Goliath lifting loop

Figure 13 shows a measurement sketch for the Goliath lifting loop.

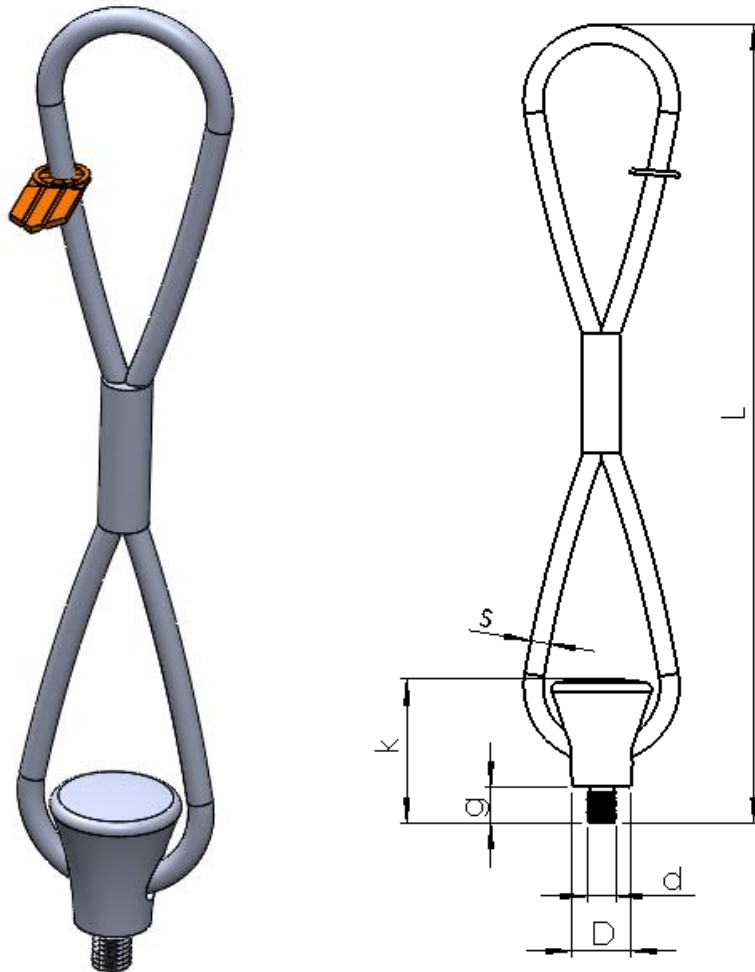

Figure 13 Goliath lifting loop dimension sketch.

19.1 Technical data

Table 16 shows the dimensions of the various types of Goliath lifting loop.

Load group	Length of lifting loop L mm	Diameter of wire s mm	Diameter of ring D mm	Ring height k mm	Thread d mm	Thread length g mm
0.5S	335	8	24	60	12	15
1.2S	365	9	24	60	16	20
2S	470	12	44	102	20	25
2.5S	550	14	44	102	24	30

Table 16 Goliath lifting loop dimension.

20 EC – Declaration of Conformity of the Machinery

This certificate meets the requirements of the Directive 2006/42/EC Annex II.

Manufacturer and responsible for compiling the technical documentation:

Company:	CERTEX Danmark A/S	Tel. No.:	+45 74 54 14 37
Address:	Trekanten 6-8 6500 Vojens Denmark	E-mail:	info@certex.dk

The undersigned hereby declares that the below specified tool comply with the current safety and health rules and legislation within the European Union. If any changes are made on the tool without approval from the manufacturer, this Declaration no longer applies.

Description:	Transport anchors with cross pin
Drawing No.:	XXXXXXXXXXXXXXXX
Serial No.:	XXXXXX
Lifting Capacity:	WLL pr unit
Own Weight:	Kg pr unit

Is made in accordance with the following EC-directive;
2006/42/EC

The following standards have been used:
EN 13155+A2 : 2009

Date:

For CERTEX Danmark A/S

Our industries, products & services

At CERTEX Denmark, we are a secure and reliable total supplier and partner within lifting equipment. Below is an overview of the industries we service, our product range, and the services we offer."

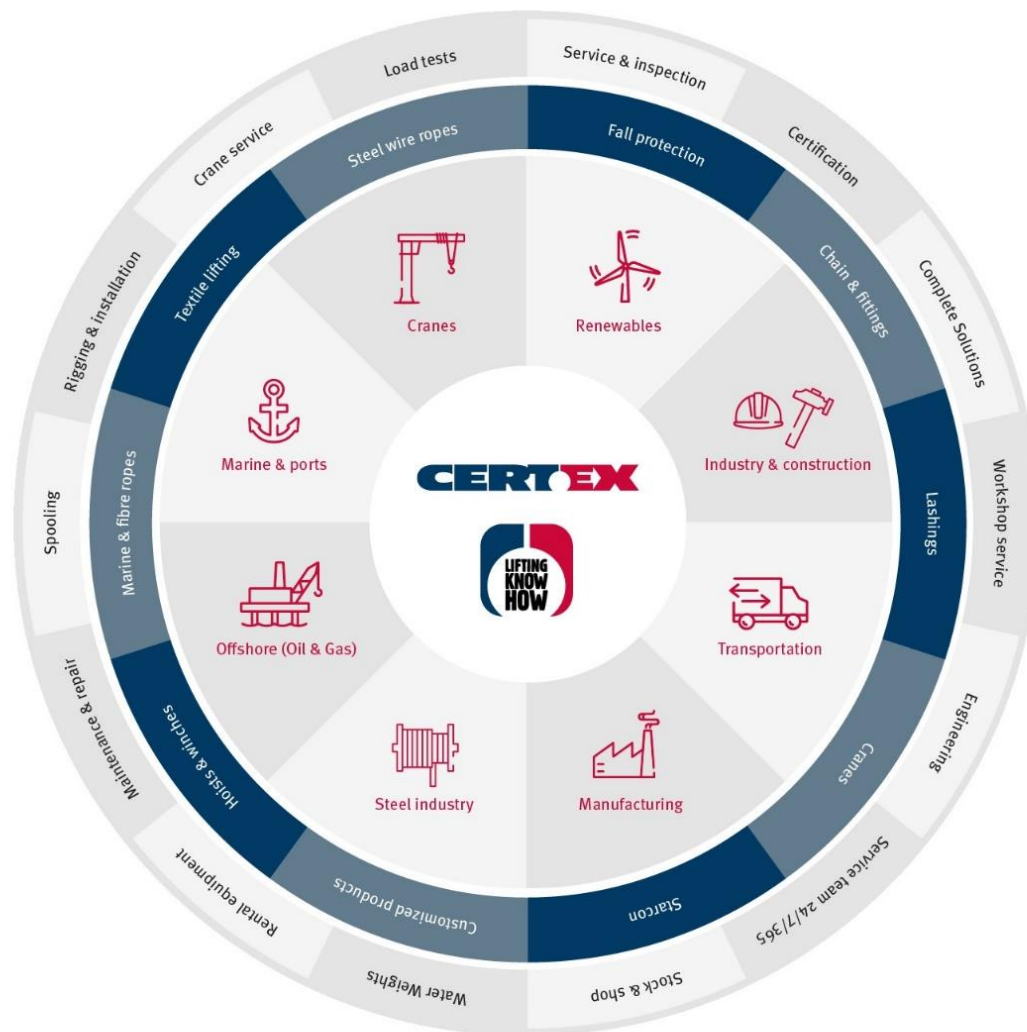

"

**Based on many years of experience
& know-how within lifting, load
tests & engineering, CERTEX
Denmark is your reliable partner &
supplier of steel wire, lifting
applications & related services."**